



MACHINERY DIVISION

6465 18 MILE ROAD
STERLING HEIGHTS, MI 48314

PHONE:
(586) 731-3600 • 1-800-860-1740

FAX:
(586) 731-7464 • 1-800-862-1740

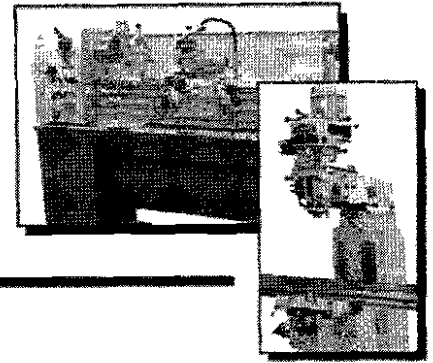

MODEL BAV-700PF BANDSAW

THANK YOU FOR PURCHASING WITH KBC MACHINERY. ALL KBC MACHINES ARE BACKED BY OUR 1 YEAR PARTS REPLACEMENT WARRANTY. WHEN USED AS INTENDED, AND WITH PROPER MAINTENANCE THIS MACHINE WILL PROVIDE YOU WITH YEARS OF TROUBLE-FREE SERVICE. IF YOU NEED PARTS SIMPLY FILL OUT THE PARTS REQUEST FORM, AND FAX OR E-MAIL YOUR REQUEST. ALL OTHER QUESTIONS PLEASE CONTACT US @ :

**KBC MACHINERY
6465 18 MILE ROAD
STERLING HEIGHTS, MI 48314
PH (800) 860-1740
FAX (800) 862-1740
MACHINERY@KBCTOOLS.COM
WWW.KBCTOOLSANDMACHINERY.COM**



PARTS REQUEST FORM

YOUR COMPANY NAME: _____

STATE/PROVINCE _____

YOUR NAME _____

PHONE # + EXT _____

FAX # _____

MACHINE INFO: _____

MAKE/MANUFACTURER _____

MODEL NUMBER _____

YEAR MADE _____

SERIAL# _____

PARTS REQUESTED:

PART#	DESCRIPTION
-------	-------------

_____	_____
-------	-------

_____	_____
-------	-------

_____	_____
-------	-------

_____	_____
-------	-------

_____	_____
-------	-------

_____	_____
-------	-------

_____	_____
-------	-------

PLEASE INCLUDE COPY(S) OF THE PARTS DRAWING FROM THE
MANUAL AND CIRCLE THE PARTS NEEDED

FAX PARTS REQUEST TO (800) 862-1740

E-MAIL PARTS REQUEST TO: machinery@kbctools.com

THANKS; KBC MACHINERY - MICHIGAN

OPERATOR'S MANUAL

BAV-360 / 450 / 500WF / 500PF / 700PF

BLADE GUIDE ADJUSTMENT:

For proper operation, the saw blade must be supported by an upper and lower saw guides. The lower guide is mounted under the table and the upper guide on a counter-balanced bar above the table. The purpose of the saw guide is to support the blade for cutting. It is very important that the guides be set in proper relation to the saw blade. To set the guides to the saw blade, set tension on blade and start the saw to check tracking on band wheel. Set dowel pin (A) Fig. 1 1/64" from the back edge of saw blade when blade is running not loaded, and then set the guide inserts (B) Fig. 1 as close to the saw as possible without causing friction or binding. Guide blocks are held in place with socket head set screws (C) Fig. 1. The guides should be set so that edge of the guides are just behind saw teeth gullets. The blade guides are fully and independently adjustable for blade width and thickness to permit the exact settings required for accurate work and prolonged blade life.

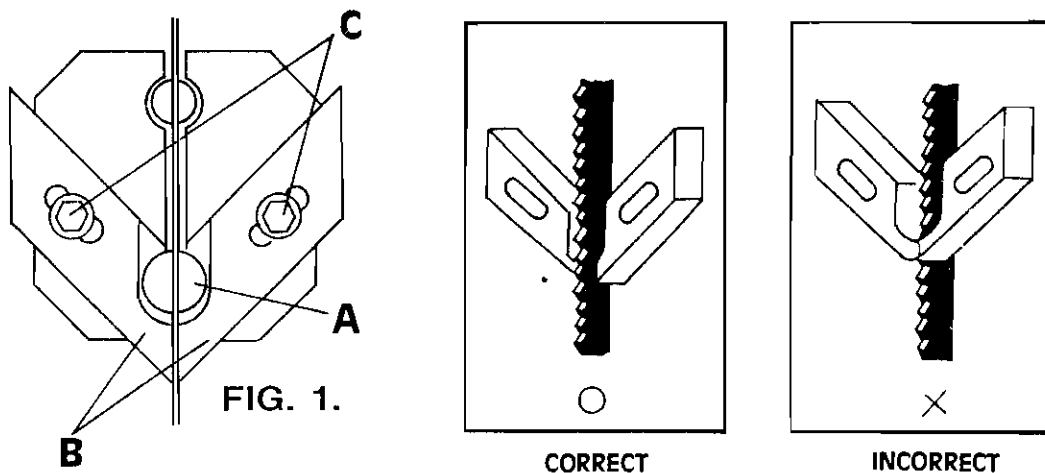

The front end of blade guide is more vulnerable to wearing out. If there is any difficulty in adjusting blade guide, turn the left blade guide over to the right side, and turn the right side blade guide over to the left side as well. The blade guide can thus be used on both sides.

The dowel pin wears out as it is used and its friction with the saw blade may cause a worn line in its surface. If this is found, loosen the set screw and turn the dowel pin to either side and then fasten the screw.

SETTING OF SAW BLADES:

Our sawing machines are so designed to have such versatility to be compatible to any types of blades.

- 1). Open both doors on machine to insert saw blade.
- 2). Adjust blade tension by turning tension adjuster.
- 3). Close the doors before running the machine.

GUIDE POST ADJUSTMENT:

- 1). Loose the guide post locker.
- 2). Lower down or raise the guide post according to the thickness of the work piece. The height between the work piece and blade guide should be around $\frac{1}{4}$ " (6mm).
- 3). Lock the guide post tightly.

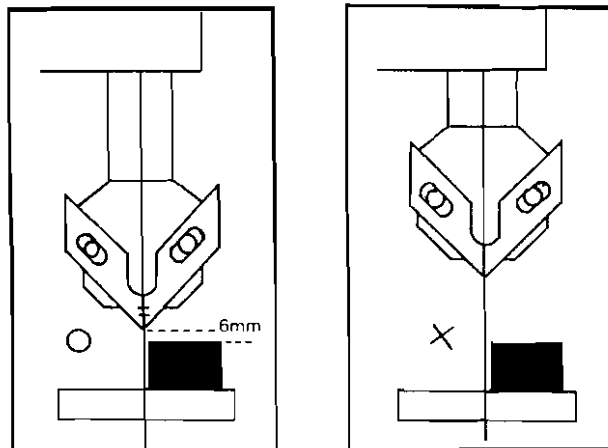

CORRECT

INCORRECT

REPLACING SAW PULLEY TIRE:

For speed range at 20-760 m/min. (65-2493 ft/min.) or lower:

Remove the pulley from the machine, pry off the old tire, then stretch the new tire over the pulley and make certain that the tire edges are down tight into the groove.

For speed range at 15-1200 m/min. (50-3936 ft/min.) or higher:

Remove the pulley from the machine, pry off the old tire, and clean all the old glue off the pulley with Ethyl Acetate solution. Apply 3M brand No. 1711S/G or equivalent rubber adhesive to the cleaned pulley and allow it to set until it becomes tacky. While the glue is tacky, stretch the tire over the pulley and make certain that the tire edge is perfectly engaged in the groove. This will assure good solid contact and a true running face.

It is essential that the rubbers on the faces are kept at an even thickness by truing up occasionally. This is done by revolving the pulleys and holding a wooden block covered with emery cloth or sandpaper against them. Care should be taken to ensure that, after truing, the wheels have a curved surface with the highest point in the center of wheel rim. This is most important for correct tracking of the saw blade. Badly worn out rubbers should be replaced by new ones. If the machine operates with badly worn rubbers the saw will vibrate, resulting in bad sawing and saw breakage.

TABLE FEED:

D-series:

To reduce packing measurement to cut down freight, the auto-sliding table is separated from main body of machine for packing. The following procedures are applicable to assembly of the unit:

- 1). Place the sliding rack onto the machine to be followed by an alignment, fastening of set screws; insert the taper pin onto the rear support to form 90 degree angle between work table and saw band.
- 2). Set the work table and see that the 4 sets of sliding bearings are fully engaged into sliding track; use hands to push the sliding mechanism forward and backward for several times to assure if it moves smoothly. If the mechanism is much too tight that it fails to slide or too loose to shake laterally, adjust the gliding bearings to their proper position.
- 3). Get the chain at rear of work table engaged into gear of motor, have the chain passed the idle wheel at back of sliding rack and have one end of the chain locked up onto a locking knob at rear of work table.
- 4). Set one each auto-stopper switch for forward and backward movement at right rear of work table and right front of work table.

CAUTION: As the work table is not built in onto main body of the machine, it is most important to lock up the lock pin in front of work table and tie the work table onto machine with rigid rope whenever you try to move the machine. This is absolutely necessary to prevent any hazards caused by coming off of work table.

H-series:

The table feed unit consists of a surge tank, relief valve, regulating valve, four way operating valve, and a hydraulic cylinder. The regulating valve is located at the left side of the table. It can be adjusted to provide a feed pressure from 0–200 kilograms.

If the table feed has a jerking motion during the feed cycle, it may be caused by air in the oil line or insufficient oil in the tank. Air in the oil line can be removed by cycling the table feed for several rounds. If this does not stop the jerking motion, add oil in the tank and repeat above procedure.

LUBRICATING INSTRUCTIONS:

The transmission case requires 1.2 quarts of heavy medium oil or its equivalent. This is prefilled at the factory. Oil for the transmission is first replaced in 100 hours after initial operation, and then 500 hours and every 1000 hours.

Please grease guide post, gear, thread and shaft of variable speed pulley at an interval of 10 days.

OPERATION OF THE WELDER:

CAUTION: 1. Ensure no rust dust or oil on saw blade, and cutting tangent must be 90 degree.

2. For welding, saw blade should be close to electrodes and keep it straight.
3. Always lock cam pivots while welding or annealing.

For welder with a capacity of 3-15mm or lower:

WELDING: 1. Turn the pressure knob to "0" position.

2. Put blade ends together and lock the joint in the center between two electrodes.
3. Set pressure knob to a proper position in keeping with blade width.
4. Press welder button until the blade joint returns to original color.

ANNEALING: 1. Return pressure knob to "0" position.

2. Release blade and lock it at the front of two electrodes.
3. Press annealing button, release it immediately after the blade joint turns to "garnet" color.
4. Repeat operation 3 for four or five times, gradually reducing heat each time by shortening the time for pressing on annealing button.
5. Grind off fusion burrs from the joint and repeat annealing in width of 5mm right and left of the joint each for three or four times, successively at lower temperature than operation 4, and the last optimum temperature should be around 500°C (No red color visible at joint section).

For welder with capacity of 3-19mm, 3-21mm or 3-25mm:

WELDING: 1. Turn pressure knob to position "S2" for 3-10mm or "S1" for 11-19mm (11-21mm, 11-25mm).

2. Put blade ends together and lock the joint in the center between two electrodes.
3. Set pressure knob to proper position in keeping with blade width.
4. Press welder button until the blade joint returns to original color.

ANNEALING: 1. Return pressure knob to "S1" position.

2. Release blade and lock it at the front of two electrodes.
3. Adjust annealing strong-weak adjuster downwards for 3-10mm or

ght. upwards for 11-19mm (11-21mm, 11-25mm).

4. Press annealing button, release it immediately after the blade joint turns to "garnet" color.
5. Repeat operation 4 for four or five times, gradually reducing heat each time by shortening the time for pressing on annealing button.
- two 6. Grind off fusion burrs from the joint each for three or four times, successively at lower temperature than operation 5, and the last optimum temperature should be around 500°C (No red color visible at joint section).

rns

eat

of
si-
m
nt

n

o

TROUBLESHOOTING

PROBLEM	CAUSE	SOLUTION
Blade develops camber	<ol style="list-style-type: none"> 1. Feed pressure too heavy 2. Saw guides too far apart 3. Roller guides not properly adjusted 4. Saw band pitch too fine 	readjust adjust closer to the work readjust use a coarser pitch
Blade develops twist	<ol style="list-style-type: none"> 1. Saw is binding in cut 2. Saw guide inserts or rollers too close to saw 3. Wrong width of blade for radius being cut 4. Too much blade tension 	reduce feed rate readjust use narrower band-saw reduce
Saw dulls prematurely	<ol style="list-style-type: none"> 1. Band velocity too high 2. Feed rate too light 3. Too coarse pitch 4. Saw idling through cut 5. Coolant improperly directed 6. Improper break-in on new blade 7. Improper saw guides for band width 	reduce increase use finer pitch keep teeth engaged- use positive feed pressure apply at point of cut reduce feed rate by half on first few cuts replace with correct ones
Saw loses set prematurely	<ol style="list-style-type: none"> 1. Saw speed too fast 2. Saw rubbing against vise or running deep in guides 	decrease speed check travel
Saw vibrates in cut	<ol style="list-style-type: none"> 1. Wrong speed for material and thickness 2. Insufficient blade tension 3. Pitch too coarse 4. Incorrect feed pressure 	see section on recommended speed and feed increase tension select finer pitch adjust
Saw teeth rip out	<ol style="list-style-type: none"> 1. Pitch too coarse 2. Gullets loading 3. Excessive feed pressure 4. Too slow speed 	use finer pitch on thin sections use coarser pitch or higher viscosity lubricant or attach brush to remove chip reduce increase

PROBLEM	CAUSE	SOLUTION
Saw blade breaks prematurely	<ol style="list-style-type: none"> 1. Speed too low 2. Too much feed 3. Blade too thick for diameter of wheels 4. Pitch too coarse 5. Excessive blade tension 6. Guides too tight or out of adjustment. 	<p>increase</p> <p>decrease use lighter gage</p> <p>use finer pitch reduce tension readjust</p>
Blade stalls in work-piece	<ol style="list-style-type: none"> 1. Feed pressure too great 	decrease
Bandsaw blade squeals while sawing	<ol style="list-style-type: none"> 1. Too low feed 2. Not tracking properly 	<p>increase pressure</p> <p>adjust</p>
Cutting rate too slow		<p>increase speed</p> <p>increase feed</p> <p>use a coarser pitch blade</p>
Bandsaw blade gullets loading up	<ol style="list-style-type: none"> 1. Too fine pitch 2. Band speed too great 	<p>use coarser pitch</p> <p>reduce</p>
Chips welding to bandsaw blade teeth	<ol style="list-style-type: none"> 1. Feed force too heavy 2. Chip brush out of alignment 	<p>reduce</p> <p>adjust</p>
Bandsaw becomes scored	<ol style="list-style-type: none"> 1. Saw guides worn 2. Guides out of alignment 3. Guides too tight 	<p>replace</p> <p>adjust adjust</p>
Crooked cutting	<ol style="list-style-type: none"> 1. Guides out of adjustment 2. Guides worn 3. Too heavy feed 4. Blade badly worn 5. Guide arms too far apart from workpiece 6. Blade tension low 	<p>readjust</p> <p>repair or replace</p> <p>reduce</p> <p>replace</p> <p>adjust</p> <p>adjust</p>
The Weld could not be made, the jaws do not move	<ol style="list-style-type: none"> 1. The wire connection is poor, the connecting point of welding switch is bad 2. The transformer is burnt out 3. Some oil is on the blade 4. Some rust is on the blade ends 5. The adjustment of welding pressure adjuster is poor. 	<p>Change a switch or grind the connecting point with a file.</p> <p>Change a transformer or rewire it.</p> <p>Remove the oil</p> <p>Grind off the rust</p> <p>Loose the adjusting screw that is in center of it.</p>

PROBLEM	CAUSE	SOLUTION
The weld area is melt when push the welding switch	<ol style="list-style-type: none"> 1. The welding switch cut off too late. 2. The welding pressure is too weak 3. The jaw movement is too slow. 	<p>Screw the welding switch connecting nut tight</p> <p>Turn the welding pressure adjuster clockwise</p> <p>Put some oil on the rear side of the welding lever and the two jaws.</p>
The annealing job can not be made when push the annealing button.	<ol style="list-style-type: none"> 1. The connection of annealing switch is poor 2. The fuse is broken 3. The connection of the conductor is poor 	<p>Change an Anneal Switch</p> <p>Change a fuse</p> <p>Change a conductor</p>
The Grinder is not running when put the grinder switch on.	<ol style="list-style-type: none"> 1. The grinder motor is burnt out 2. The grinder switch is out of order 	<p>Change a grinder motor or rewire it</p> <p>Change a switch</p>
The blade can not be tightly clamped with the jaw clampers.	<ol style="list-style-type: none"> 1. The jaw clampers are out of order 2. The lower jaw inserts are out of 3. The jaws are decayed. 	<p>Change Clampers</p> <p>Change lower jaw inserts</p> <p>Change jaws</p>

PART NO. DESCRIPTION

- 001 BEARING
- 002 BEARING
- 004 BEARING
- 011 MOTOR
- 014 BEARING
- 016 ROLLER CHAIN
- 017 V BELT
- 018 V BELT
- 019 V BELT
- 020 V BELT
- 201 PULLEY
- 202 VARIABLE SPEED WHEEL
- 203 VARIABLE SPEED WHEEL
- 204 VARIABLE SPEED SHAFT
- 205 SHAFT
- 209 SPROCKET GEAR
- 210 PULLEY
- 211 WASHER
- 212 PULLEY PIVOT
- 213 PULLEY
- 214 BEARING SEAT
- 215 SHAFT
- 216 SPROCKET WHEEL
- 217 SPROCKET MOUNT
- 219 SHAFT
- 220 BEARING SEAT
- 221 DRIVING UNITS SADDLE
- 222 DRIVING UNITS SADDLE
- 223 ROCKING ARM SADDLE
- 225 ROCKING ARM BLOCK
- 226 SHAFT
- 227 PULLEY
- 228 RETAINER RING
- 229 BEARING STAND
- 230 UNION LINK
- 231 ROCKING ARM
- 234 SHAFT
- 246 SCREWED SHAFT
- 247 SLIDE BAR
- 248 THIMBLE
- 249 BEVEL GEAR
- 250 THIMBLE
- 251 SPEED TRANSMISSION SADDLE
- 297 RETAINER RING
- 298 GREASE NOZZLE
- 299 RETAINER RING
- 301 RUBBER BELT
- 302 RUBBER BELT
- 303 TAPER SLEEVE
- 304 LOCK NUT

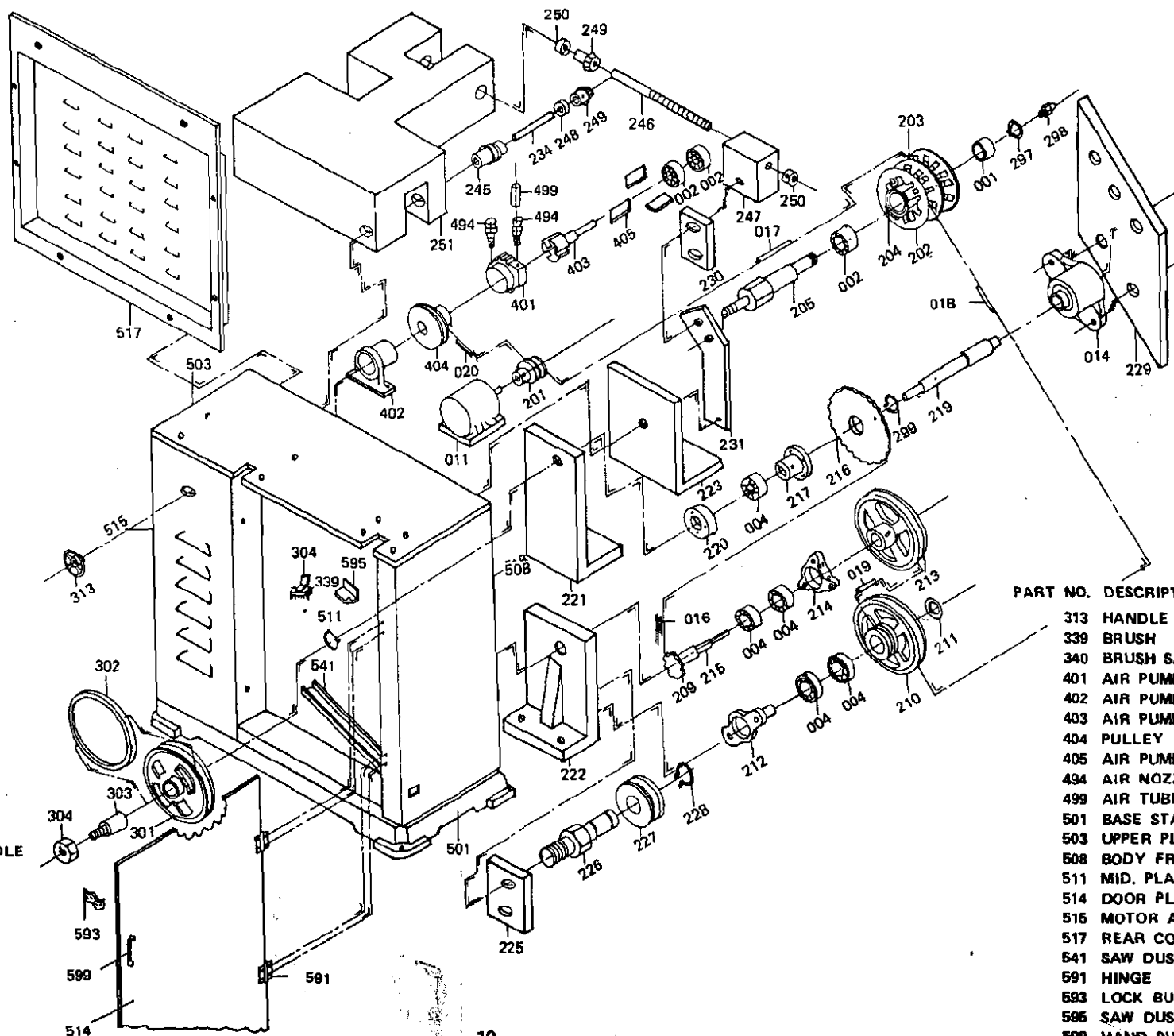

PART NO. DESCRIPTION

- 313 HANDLE WHEEL
- 339 BRUSH
- 340 BRUSH SADDLE
- 401 AIR PUMP CASTING
- 402 AIR PUMP SADDLE
- 403 AIR PUMP ROTOR
- 404 PULLEY
- 405 AIR PUMP BLADE
- 494 AIR NOZZLE
- 499 AIR TUBE
- 501 BASE STAND
- 503 UPPER PLATE
- 508 BODY FRAME
- 511 MID. PLATE
- 514 DOOR PLATE
- 515 MOTOR APRON PLATE
- 517 REAR COVER
- 541 SAW DUST COLLECTOR
- 591 HINGE
- 593 LOCK BUTTON
- 595 SAW DUST PLATE
- 599 HAND PULL

MODEL: 400, 500, 700, 1000, 400D, 500D, 700D, 1000D, 500H, 700H & 1000H

PART NO.	DESCRIPTION
003	BLADE TENSION ADJUSTER
101	TABLE
102	SUPPORTING FRAME
103	BRACKET, RIGHT
104	BRACKET, LEFT
107	BUSHING
109	SUPPORT
110	BLADE GUIDE SUPPORT SEAT
111	SET SCREW
112	LEVER
113	KNOB
131	BLADE GUIDE SUPPORT
132	BLADE GUIDE
133	SUPPORTING PIN
134	PIN
135	GUIDE POST
136	SLIDE GUIDE
137	BLADE GUARD
138	BLADE GUARD
139	SCREW
140	KNOB
141	SCREW
155	FEED BAR
156	SLIPPER
157	NUT
158	SCREW WIHT KNOB
302	RUBBER TIRE
305	DRIVEN WHEEL
306	LOCK NUT
307	NUT
313	HANDWHEEL
314	WASHER
331	BEVEL GEAR
332	SHAFT
333	BEVEL GEAL
497	CLIP
498	AIR NOZZLE
499	TUBE
502	MAIN CASTING
504	SLIDE COVER
505	UPPER COVER
591	HINGE
599	HANDLE
635	WORK LAMP
909	BEARING

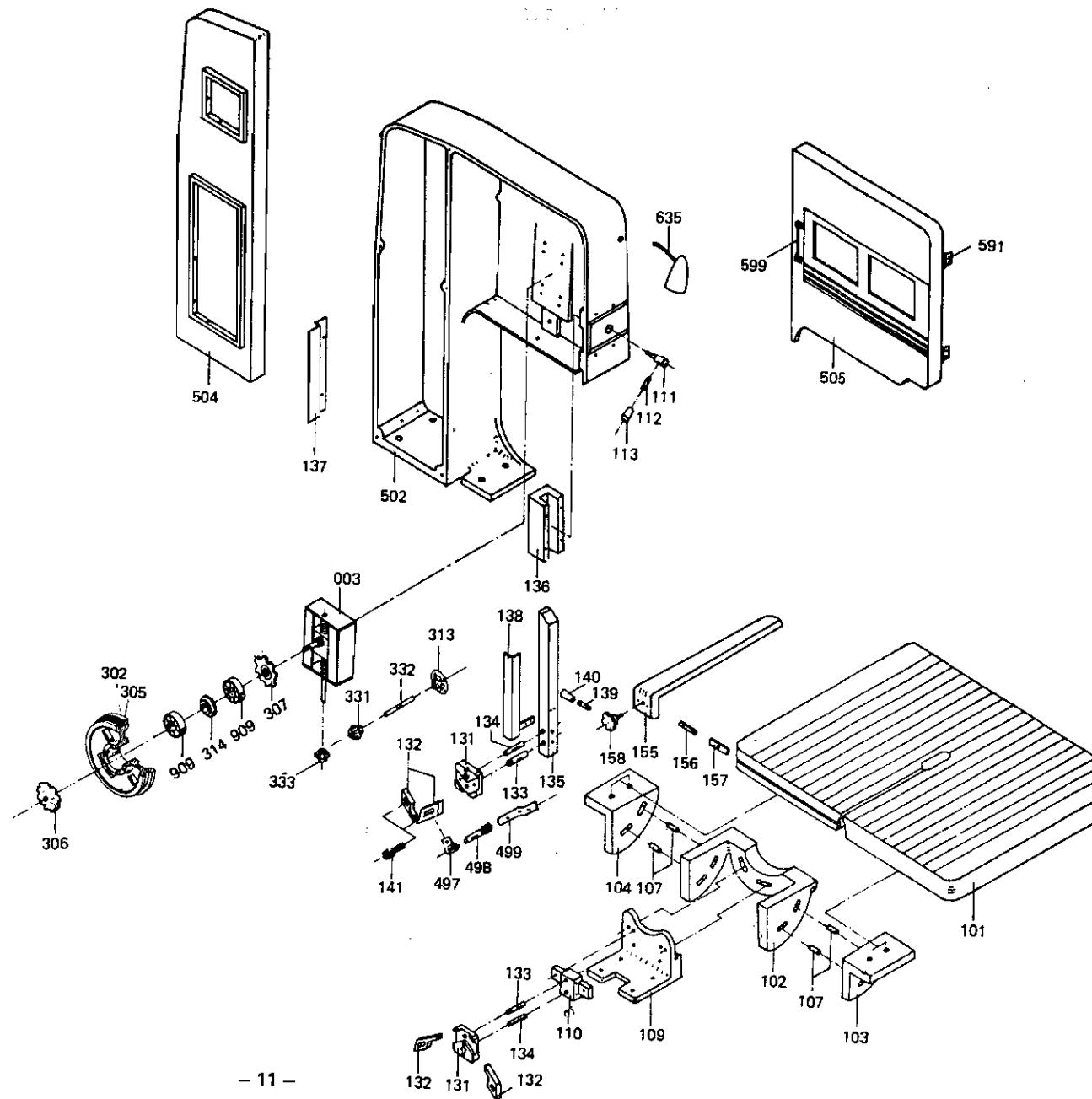

PART NO. DFSCRIPTION

PART NO. DESCRIPTION

- 001 BEARING
- 002 BEARING
- 004 BEARING
- 010 GEAR BOX
- 011 MOTOR
- 012 LEVER MOUNT
- 013 LEVER
- 014 BEARING
- 015 KNOB
- 016 ROLLER CHAIN
- 017 V BELT A37
- 018 V BELT A39
- 019 V BELT A47
- 020 V BELT M19
- 201 PULLEY
- 202 VARIABLE SPEED WHEEL
- 203 VARIABLE SPEED WHEEL
- 204 VARIABLE SPEED SHAFT
- 205 SHAFT
- 209 SPROCKET GEAR
- 210 PULLEY
- 211 WASHER
- 212 PULLEY PIVOT
- 213 PULLEY
- 214 BEARING SEAT
- 215 SHAFT
- 216 SPROCKET WHEEL
- 217 SPROCKET MOUNT
- 219 SHAFT
- 220 BEARING SEAT
- 221 DRIVING UNITS SADDLE
- 222 DRIVING UNITS SADDLE
- 223 ROCKING ARM SADDLE
- 225 ROCKING ARM BLOCK
- 226 SHAFT
- 227 PULLEY
- 228 RETAINER RING
- 230 UNION LINK
- 231 ROCKING ARM
- 232 SPROCKET GEAR
- 234 SHAFT
- 236 SHAFT SADDLE
- 243 SPROCKET GEAR
- 244 WORM GEAR
- 245 WORM
- 246 SCREWED SHAFT
- 247 SLIDE BAR
- 248 THIMBLE
- 249 BEVEL GEAR
- 250 THIMBLE

- 251 SPEED TRANSMISSION SADDLE
- 252 GEAR BOX BLOCK
- 253 WORM GEAR SADDLE
- 254 WORM GEAR SADDLE
- 255 SPEED PLATE
- 297 RETAINER RING
- 298 GREASE NOZZLE
- 299 RETAINER RING
- 301 DRIVING WHEEL
- 302 RUBBER BELT
- 303 TAPER SLEEVE
- 304 LOCK NUT
- 313 HANDLE WHEEL
- 339 BRUSH
- 340 BRUSH SADDLE
- 401 AIR PUMP CASTING
- 402 AIR PUMP SADDLE
- 403 AIR PUMP ROTOR
- 404 PULLEY
- 405 AIR PUMP BLADE
- 494 AIR NOZZLE
- 499 AIR TUBE
- 501 BASE STAND
- 503 UPPER PLATE
- 508 BODY FRAME
- 511 MID. PLATE
- 514 DOOR PLATE
- 515 MOTOR APRON PLATE
- 517 REAR COVER
- 541 SAW DUST COLLECTOR
- 591 HINGE
- 593 LOCK BUTTON
- 595 SAW DUST PLATE
- 599 HAND PULL

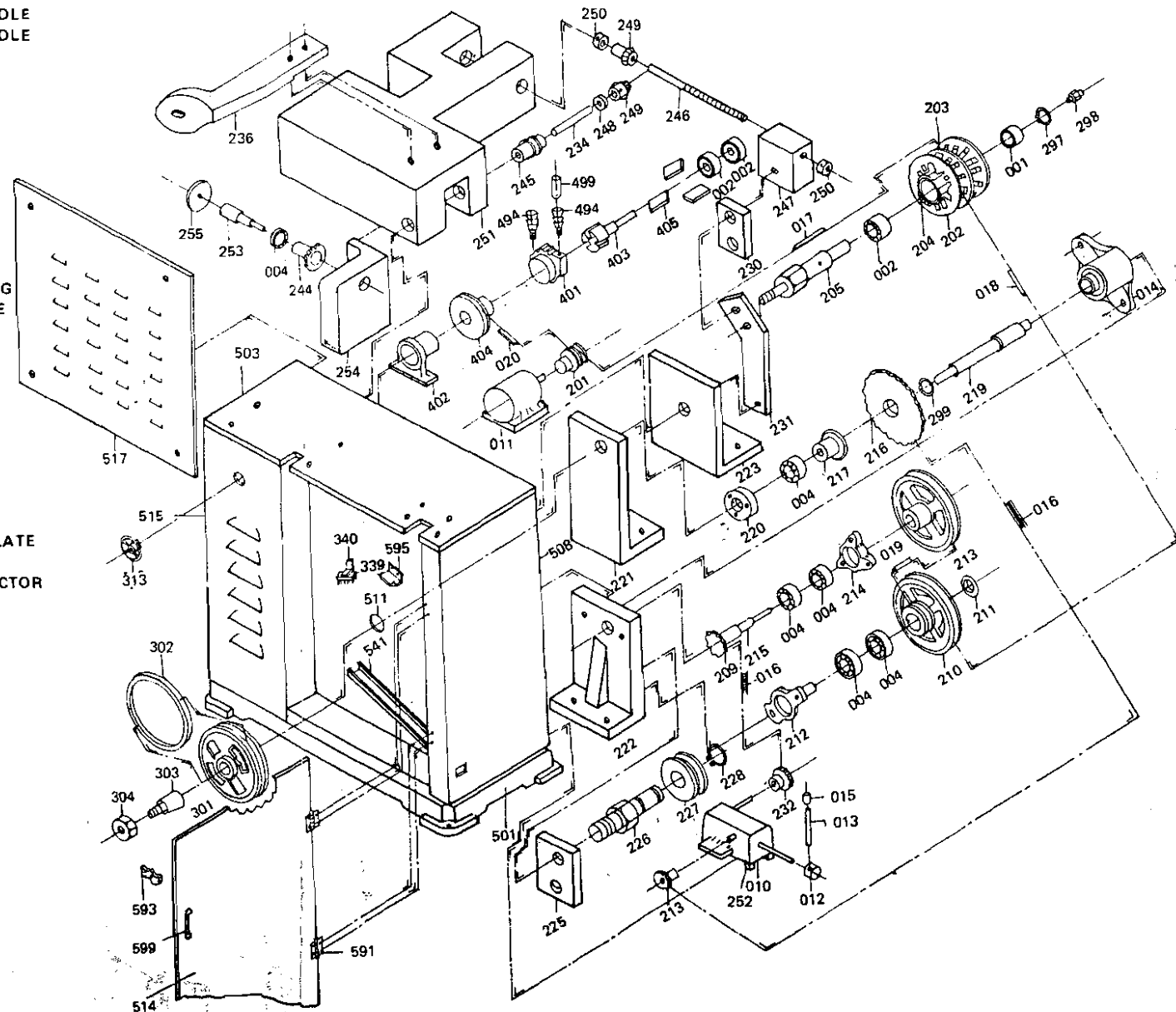

SAW BLADE WELDER

PART NO. DESCRIPTION

- 194 SHEAR SEAT
- 195 LOWER SHEAR BLADE
- 196 UPPER SHEAR BLADE
- 197 LOCKING LINK
- 198 LINK
- 199 LEVER
- 601 SWITCH
- 602 SLIDE BLOCK
- 603 SLIDE SEAT
- 604 HOUSING
- 605 ELECTRODE
- 606 CAM PIVOT
- 607 CAM
- 607R CAM
- 608L LEVER
- 608R LEVER
- 609 KNOB
- 610 CLAMP
- 611 CONNECTING PLATE
- 613 ELECTRODE
- 614 RETAINER
- 615 WELDING SWITCH
- 616 ANNEALING SWITCH
- 617 WELDING PRESSURE ADJUSTER
- 618 BOLT
- 619 TRIANGULAR FIXTURE
- 620 CAM
- 621 ARM
- 622 SPRING
- 623 SPRING
- 624 TRANSFORMER
- 625 GRINDER SWITCH
- 626 GRINDER MOTOR
- 627 CAPACITOR
- 628 GRINDING WHEEL
- 629 WHEEL GUARD
- 633 NAME PLATE
- 634 INSTRUCTION

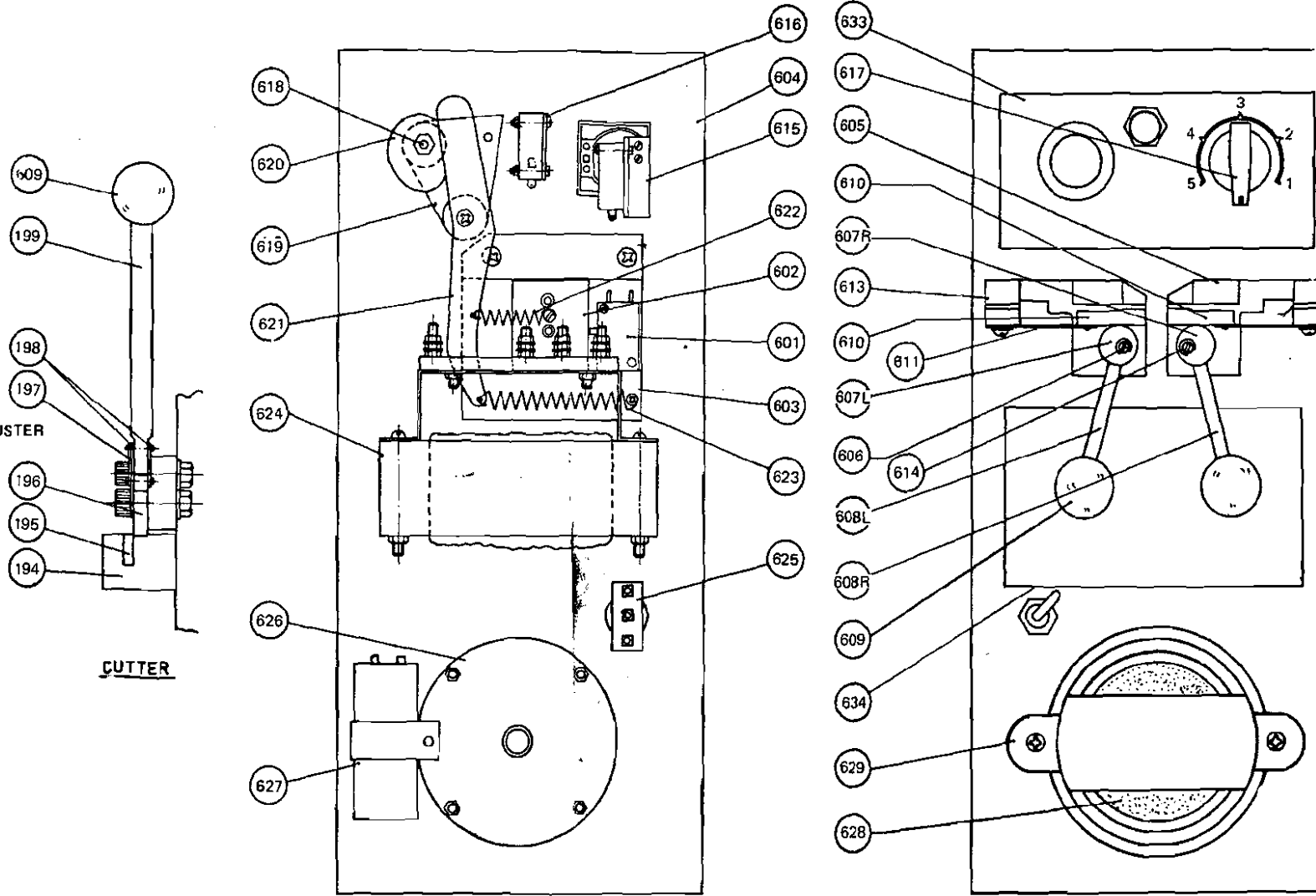

MODEL: 500H, 700H, 1000H, HYDRAULIC POWERED TABLE

PART NO	DESCRIPTION	PART NO.	DESCRIPTION
030	SOC HD CAP SCREW	804	CYLINDER
031	SPRING WASHER	941	WORK HOLDING JAW
032	SOC HEADLESS SET SCREW	950	SHAFT
033	NUT	951	BEARING
034	SOC HEADLESS SET SCREW	952	TABLE SUPPORTING RACK
035	SOC HD CAP SCREW	953	NUT
036	SPRING WASHER	954	WASHER
037	C RING	956	NUT
038	NUT	957	BLADE GUIDE BRACLET
039	SPRING WASHER	960	SUPPORTING BLOCK, CIRCLE CUTTING ATTACH.
040	SOC HD CAP SCREW	961	TRUNNION, CIRCLE CUTTING ATTACH.
041	SPRING WASHER	962	SUPPORTING BLOCK
042	SOC HD CAP SCREW	963	CONNECTING FRAME
043	SPRING WASHER	964	SHAFT
044	SOC HEADLESS SET SCREW	965	SHAFT
045	SPRING WASHER	966	CENTER PIN
046	SOC HD CAP SCREW	967	SPECIAL NUT
047	NUT	968	SPECIAL SCREW
048	SOC HEADLESS SET SCREW	970	SECURE BLOCK
049	SPRING WASHER	971	CONNECTING SCREW
050	SPRING WASHER	972	BAR
051	C RING	973	SPECIAL NUT
052	SOC HEADLESS SET SCREW	974	PLASTIC NUT
053	SOC HD SET SCREW	975	NUT
054	SPRING WASHER	977	SPECIAL SCREW
055	SOC HEADLESS SET SCREW	978	LOCKING BLOCK
056	SOC HD CAP SCREW	980	SUPPORTING BLOCK
057	SPRING WASHER	981	SUPPORTING BAR
058	WASHER	982	LOCK NUT
059	NUT	983	SUPPORTING RACK
060	SOC HD CAP SCREW	984	SPINDLE
061	LOCKER	985	WHEEL
101	TABLE WITH T SLOTS		
102	TABLE SUPPORTING FRAME		
109	BRACKET, CENTER		
110	BLADE GUIDE SUPPORTING SEAT		
131	BLADE GUIDE SUPPORT		
132	BLADE GUIDE		
133	SUPPORTING PIN		
134	PIN		
135	GUIDE POST		
141	SCREW		
150	SPACER		
151	RULLER BAR		
152	POINTER		
801	CYLINDER		

MODEL: 360D, 400D, 500D, 700D, 1000D,
AUTO - SLIDING TABLE

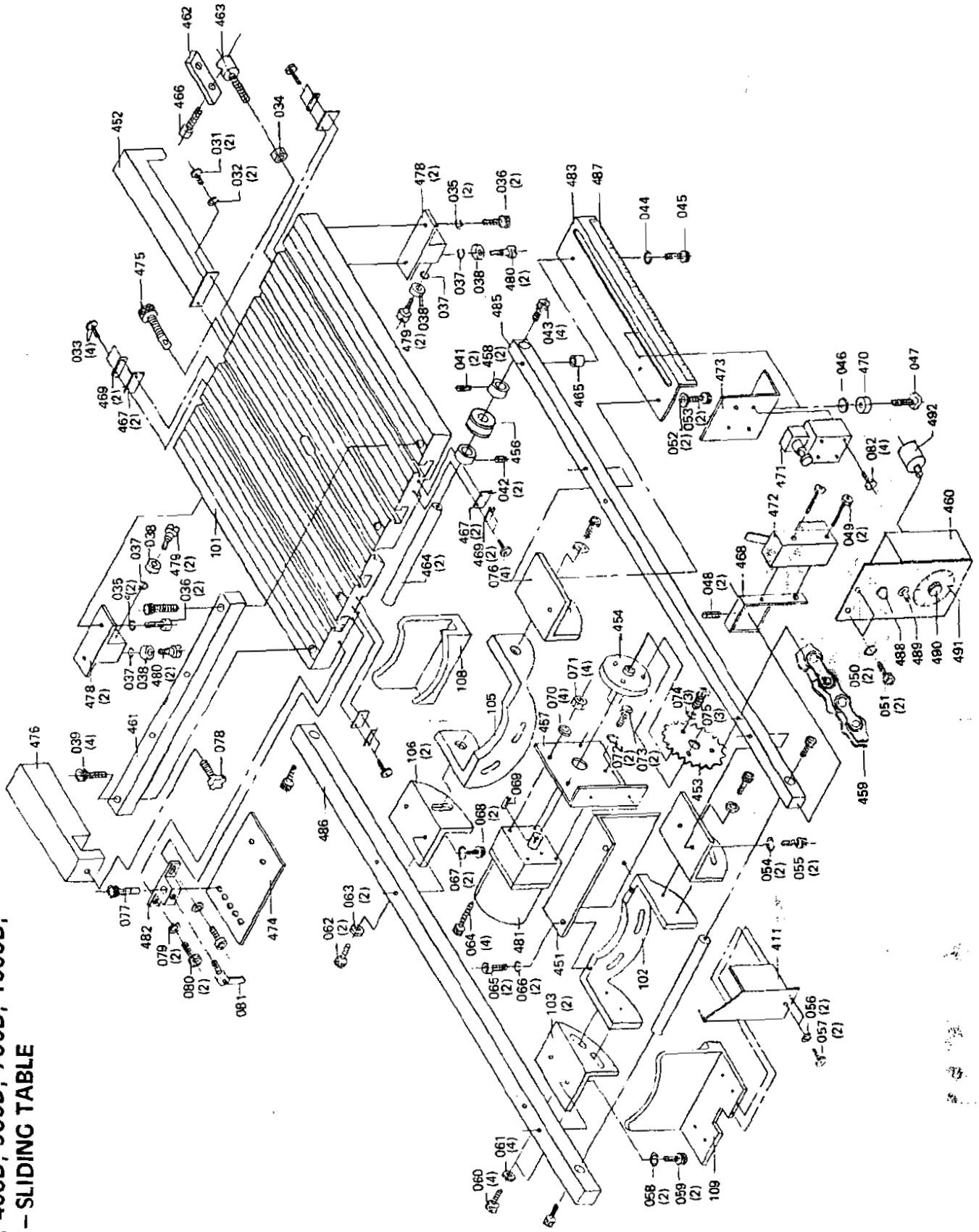

PART NO. DESCRIPTION

031 FLAT HD SOC SCREW
 032 SPRING WASHER
 033 FLAT HD SOC SCREW
 034 NUT
 035 SPRING WASHER
 036 SOC HD CAP SCREW
 037 C RING
 038 BEARING
 039 SOC HD CAP SCREW
 041 SOC HEADLESS SET
 042 SOC HEADLESS SET SCREW
 043 SOC HD CAP SCREW
 044 SPRING WASHER
 045 SOC HD CAP SCREW
 046 WASHER
 047 SPECIAL SCREW
 048 SOC HEADLESS SET SCREW
 049 FLAT HD SOC SCREW
 050 SPRING WASHER
 051 SOC HD CAP SCREW
 052 WASHER
 053 SOC HD CAP SCREW
 054 SPRING WASHER
 055 SOC HD CAP SCREW
 056 SPRING WASHER
 057 FLAT HD SOC SCREW
 058 SPRING WASHER
 059 SOC HD CAP SCREW
 060 SOC HD CAP SCREW
 061 WASHER
 062 SOC HD CAP SCREW
 063 SOC HD CAP SCREW
 064 SOC HD CAP SCREW
 065 SOC HD SCREW
 066 SPRING WASHER
 067 SPRING WASHER
 068 SOC HD CAP SCREW
 069 KEY
 070 WASHER
 071 NUT
 072 SPRING WASHER
 073 SOC HD CAP SCREW
 074 SPRING WASHER
 075 SOC HD CAP SCREW
 076 FLAT HD SOC SCREW
 077 SOC HD CAP SCREW
 078 SPECIAL SCREW
 079 WASHER

PART NO. DESCRIPTION

080 SOC HD CAP SCREW
 081 SPECIAL SCREW
 082 FLAT HD SOC SCREW
 101 TABLE
 102 SUPPORTING FRAME FRONT
 103 BRACKET, FRONT
 105 SUPPORTING FRAME, REAR
 106 BRACKET, REAR
 108 BRACKET, CENTER, REAR
 109 BRACKET, CENTER, FRONT
 411 LOWER BLADE GUARD
 451 FRAME, MOTOR RACK
 452 CHAIN COVER
 453 GEAR
 454 PULLEY, CHAIN DRIVE
 456 IDLE WHEEL
 457 MOTOR RACK
 458 SPACER
 459 CHAIN
 460 CONTROL BOX, TABLE FEED
 461 RIP FENCE RACK
 462 CHAIN LOCK
 463 SPECIAL SCREW
 464 CONNECTING BAR, SLIDING RACK
 467 DUST WIPER
 468 SWITCH CASE
 469 WASHER
 470 WASHER
 471 MICRO SWICH, FORWARD STOPPER
 472 MICRO SWITCH, REVERSE STOPPER
 473 SWITCH RACK
 474 LOCKING PLATE
 475 SPECIAL SCREW
 476 RIP FENCE
 478 BEARING RACK
 479 SPECIAL SCREW
 480 SPECIAL SCREW
 481 TORQUE MOTOR
 482 LOCKER RACK
 483 STOPPER FRAME
 485 SLIDING BAR, RIGHT SIDE
 486 SLIDING BAR, LEFT SIDE
 487 NAME PLATE
 488 PILOT LIGHT
 489 SWITCH, TABLE FEED
 490 SPEED CONTROL, TABLE FEED
 491 NAME PLATE
 492 TRANSFORMER

