



MACHINERY DIVISION

6465 18 MILE ROAD
STERLING HEIGHTS, MI 48314

PHONE:
(586) 731-3600 • 1-800-860-1740

FAX:
(586) 731-7464 • 1-800-862-1740

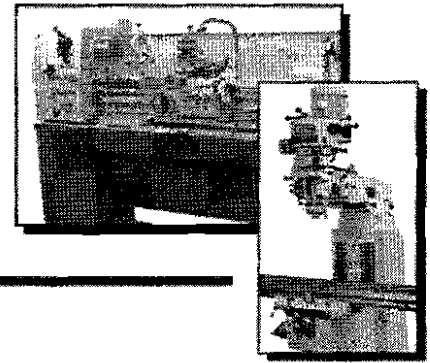

MODEL GRIP-918 LATHE

THANK YOU FOR PURCHASING WITH KBC MACHINERY. ALL KBC MACHINES ARE BACKED BY OUR 1 YEAR PARTS REPLACEMENT WARRANTY. WHEN USED AS INTENDED, AND WITH PROPER MAINTENANCE THIS MACHINE WILL PROVIDE YOU WITH YEARS OF TROUBLE-FREE SERVICE. IF YOU NEED PARTS SIMPLY FILL OUT THE PARTS REQUEST FORM, AND FAX OR E-MAIL YOUR REQUEST. ALL OTHER QUESTIONS PLEASE CONTACT US @ :

**KBC MACHINERY
6465 18 MILE ROAD
STERLING HEIGHTS, MI 48314
PH (800) 860-1740
FAX (800) 862-1740
MACHINERY@KBCTOOLS.COM
WWW.KBCTOOLSANDMACHINERY.COM**



PARTS REQUEST FORM

YOUR COMPANY NAME:

STATE/PROVINCE

YOUR NAME

PHONE # + EXT

FAX #

MACHINE INFO:

MAKE/MANUFACTURER

MODEL NUMBER

YEAR MADE

SERIAL#

PARTS REQUESTED:

PART#

DESCRIPTION

PLEASE INCLUDE COPY(S) OF THE PARTS DRAWING FROM THE
MANUAL AND CIRCLE THE PARTS NEEDED

FAX PARTS REQUEST TO (800) 862-1740

E-MAIL PARTS REQUEST TO: machinery@kbctools.com

THANKS; KBC MACHINERY - MICHIGAN

GRIP-918

OPERATOR'S MANUAL

Bench Lathe

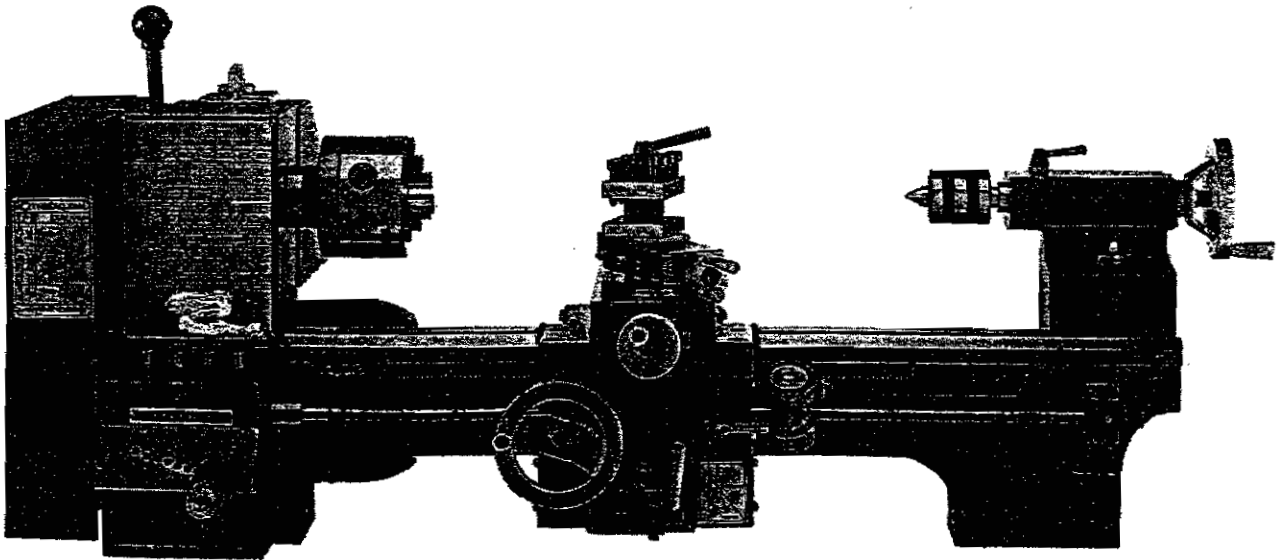

⚠ WARNING

1. Read and understand the entire instruction manual before operating machine.
2. Always wear approved safety glasses/face shields while using this machine.
3. Make certain the machine is properly grounded.
4. Before operating the machine, remove tie, rings, watches, other jewelry, and roll up sleeves above the elbows. Remove all loose clothing and confine long hair. Do NOT wear gloves.
5. Keep the floor around the machine clean and free of scrap material, oil and grease.
6. Keep machine guards in place at all times when the machine is in use. If removed for maintenance purposes, use extreme caution and replace the guards immediately.
7. Do NOT over reach. Maintain a balanced stance at all times so that you do not fall or lean against blades or other moving parts.
8. Make all machine adjustments or maintenance with the machine unplugged from the power source.
9. Use the right tool. Don't force a tool or attachment to do a job which it was not designed for.
10. Replace warning labels if they become obscured or removed.
11. Make certain the motor switch is in the OFF position before connecting the machine to the power supply.
12. Give your work undivided attention. Looking around, carrying on a conversation, and "horse-play" are careless acts that can result in serious injury.
13. Keep visitors a safe distance from the work area.
14. Use recommended accessories; improper accessories may be hazardous.
15. Make a habit of checking to see that keys and adjusting wrenches are removed before turning on the machine.
16. Never attempt any operation or adjustment if the procedure is not understood.
17. Keep fingers away from revolving parts and cutting tools while in operation.
18. Keep belt guard in place and in working order.
19. Never force the cutting action.
20. Do not attempt to adjust or remove tools during operation.
21. Always keep cutters sharp.
22. Always use identical replacement parts when servicing.
23. Failure to comply with all of these warnings may cause serious injury.

Table of Contents

Warnings..... 1
Table of Contents..... 2
Specifications..... 3
Contents of the Shipping Container..... 3
Set-Up and Preparation for Operation..... 3
General Description..... 4-6
Controls..... 7
Operation..... 8-13
Adjustments..... 14-16
Electrical Connections..... 16
Lubrication Schedule..... 17
Parts Lists and Breakdowns..... 18-41

Specifications:

Stock No. 321373
Capacities:
Swing Over Bed 9"
Swing Over Cross Slide 5-5/16"
Distance Between Centers 20"
Headstock:
Hole Through Spindle 7/8"
Spindle Nose 1-1/2" x 8 T.P.I.
Taper in Spindle Nose MT-3
Spindle Bearing Type Tapered Roller
Number of Spindle Speeds 6
Range of Spindle Speeds 130-2000 RPM
Gear Box:
Number of Longitudinal Feeds 18
Range of Longitudinal Feeds005"-.011"
Number of Inch Threads 27
Range of Inch Threads 8-56 T.P.I.
Number of Metric Threads 11
Range of Metric Threads05-3.0 mm
Leadscrew 9/16"x15 T.P.I.

Compound and Carriage:

Toolpost Type Single and 4-Way
Maximum Tool Size 1/2" x 1/2"
Maximum Compound Slide Travel 1-7/8"
Maximum Cross Slide Travel 5"
Maximum Carriage Travel 16"
Tailstock:
Tailstock Spindle Travel 1-9/16"
Diameter of Tailstock Spindle 1-1/16"
Taper in Tailstock Spindle MT-2
Miscellaneous:
Steady Rest Capacity 1/4"-1-7/8"
Follow Rest Capacity 1/4"-1-7/8"
Length of Bed 47"
Width of Bed 4-1/2"
Height of Bed 6-5/8"
Overall Dimensions ..37-1/2"Lx19-3/4"Wx15-3/4"H
Main Motor 3/4 HP, 1 Ph., 115V
Net Weight (approx.) 195 lbs.
Shipping Weight (approx.) 250 lbs.

Contents of the Shipping Container

1 Lathe	1 #1 Cross Point Screwdriver
1 7" Four-Jaw Independent Chuck	1 #1 Flat Blade Screwdriver
1 4" Three-Jaw Universal Chuck	3 Chuck Jaws
1 Faceplate	1 8/10mm Open End Wrench
1 Four Way Tool Post	1 MT-2 Center
1 Operator's Manual	1 MT-3 Center
1 Warranty Card	1 28T Gear
	1 30T Gear
	1 36T Gear
	1 42T Gear
	1 45T Gear
	1 80T Gear
	2 Chuck Keys

Toolbox Contents:

1 Steady Rest
1 Follow Rest
1 Single Tool Holder
1 5 pc. Hex Wrench Set

WARNING

Read and understand the entire contents of this manual before attempting set-up or operation! Failure to comply may cause serious injury!

Set Up and Preparation for Operation

To avoid twisting the bed, make sure the location to which the lathe is bolted is absolutely flat and level. Place a machinist's level on the bedways and check for level side to side and front to rear. If stand mounted, the stand must be fastened to the floor.

Remove rust protectant from all surfaces with kerosene, diesel oil, or a mild solvent. Do not use gasoline, paint thinner, or lacquer thinner. These will damage painted surfaces. After cleaning, wipe with a clean, dry cloth and cover all machined surfaces with a light film of machine oil.

General Description

Lathe Bed

The lathe bed is made of high grade iron. By combining high cheeks with strong cross ribs, a bed of low vibration and rigidity is produced. (Fig. 1) The two precision-ground V-slideways, re-enforced by heat hardening and grinding, are an accurate guide for the carriage and tailstock. The main motor is mounted to the rear of the bed. (Fig. 2)

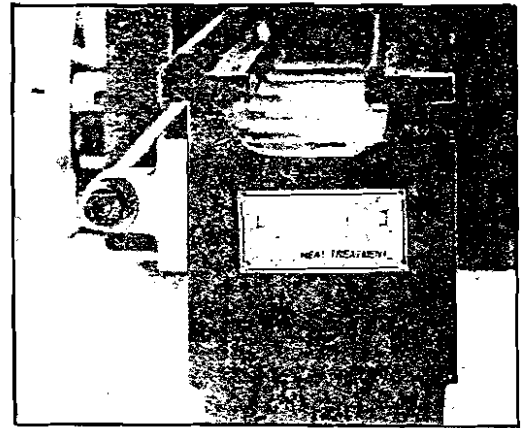

Fig. 1

Headstock

The headstock is cast from high grade, low vibration cast iron. It is bolted to the bed with four screws and uses four adjusting screws for alignment. In the head, the large main spindle is mounted on two precision taper roller bearings. The hollow spindle is a Morse taper No. 3 with a 7/8" bore. (Fig. 3)

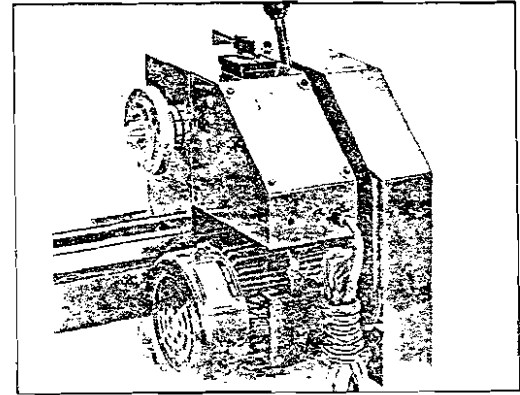

Fig. 2

A quick change of the belt can be accomplished by easing the tension on the idler. (Fig. 4)

To protect the machine against accidental damage, a clutch is fitted to the reduction pulley at the 130 R.P.M. speed.

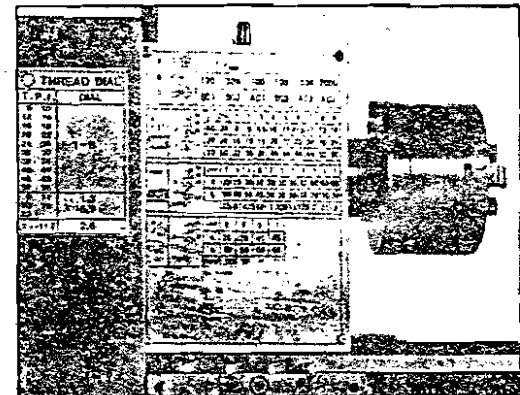

Fig. 3

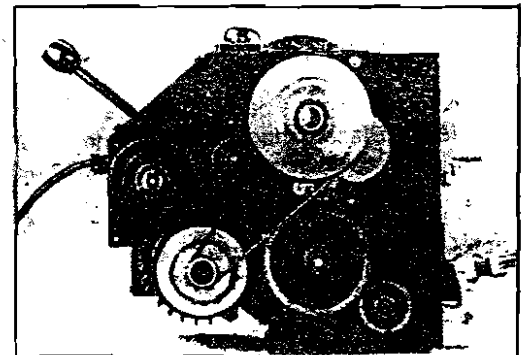

Fig. 4

Carriage

The carriage is made from high quality cast iron. The sliding parts are smooth ground. (Fig. 5) They fit the V on the bed without play. The lower sliding parts can be easily and simply adjusted. The cross slide is mounted on the carriage and moves on a dove tailed slide. Play in the cross slide may be adjusted with the gibs.

Move the cross slide with it's conveniently positioned handwheel. There is a graduated collar on the handwheel. One graduated mark equals 0.0254 millimeters or 0.001 inches. (Fig. 6)

The top slide, mounted on the cross slide, can be rotated 360°. The top slide and the cross slide travel in dove tailed slides and have gibs, adjustable nuts, and graduated collars.

A four way tool post is fitted on the top slide. The four way tool post can be converted to a single tool holder with parts enclosed in the tool box. (Fig. 6)

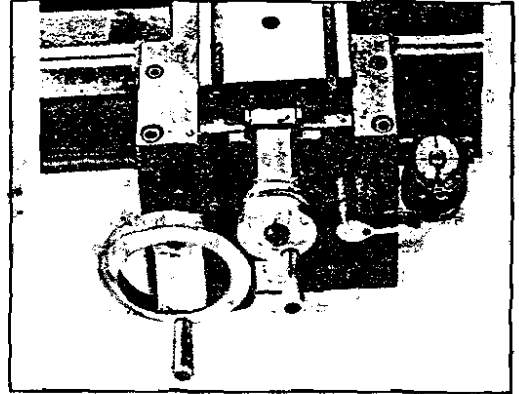

Fig. 5

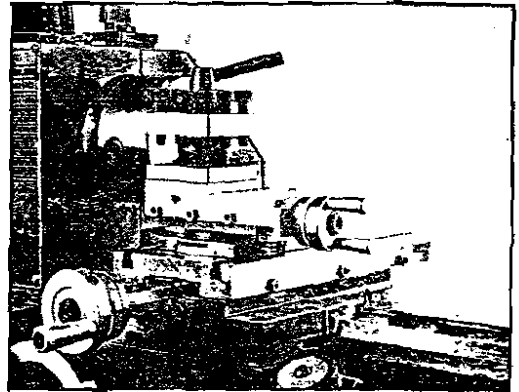

Fig. 6

For accurate facing operations, the carriage can be locked by tightening the hex socket cap screw. (A, Fig. 7)

Apron

The apron is mounted on the bed. A half nut is fitted to the apron. The half nut gibs can be adjusted from the outside.

The half nut is engaged by the half nut lever. A rack, mounted on the bed, and a pinion operated by handwheel on the carriage allow for quick travel of the apron. (Fig. 8)

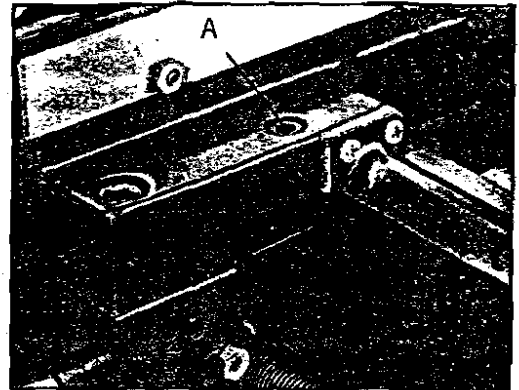

Fig. 7

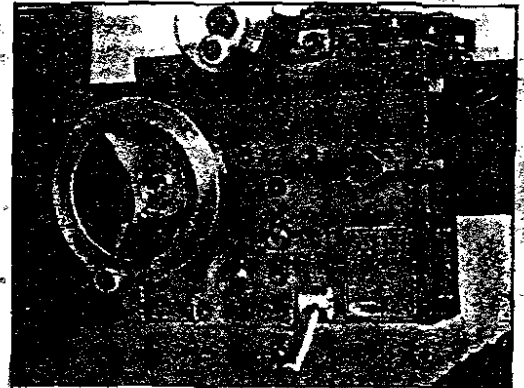

Fig. 8

Tailstock

The tailstock slides on a V way and can be clamped at any location. (Fig. 9) The tailstock has a heavy duty spindle with a Morse taper No. 2 socket and a graduated scale. The spindle can be clamped at any location with a clamping lever. The spindle is moved with a handwheel at the end of the tailstock.

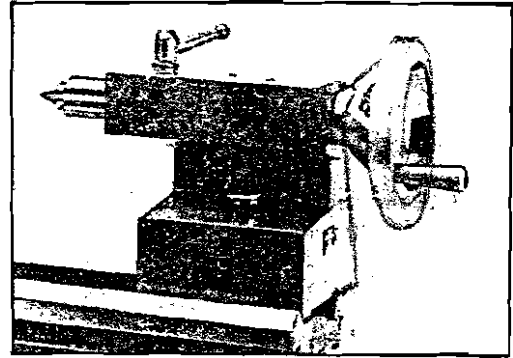

Fig. 9

Leadscrew

The leadscrew is mounted on the front of the machine bed. It is connected to the gear box at the left for automatic feed and is supported by bearing on both ends. The nut and set screw on the right end are designed to take up play on the leadscrew. (Fig. 10)

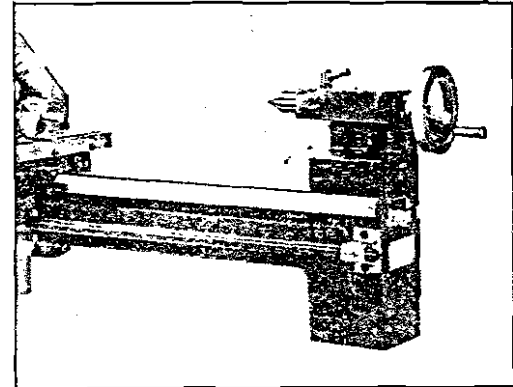

Fig. 10

Gear Box

The gear box is made from high quality cast iron and is mounted on the left side of the machine bed. (Fig. 11) The motor drives through nine changeable speeds. Always raise idler to the disengaged position when changing speeds. (A Fig. 12)

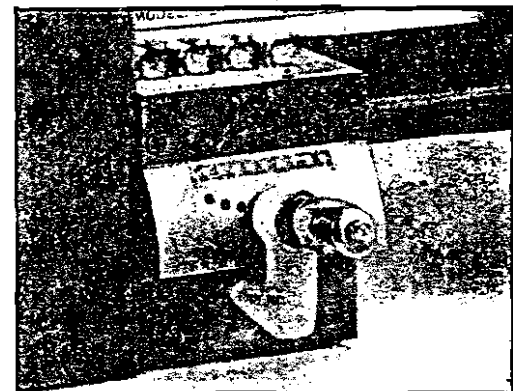

Fig. 11

Drive and Electrical Equipment

The main drive is provided by a single phase, A.C. motor mounted on the rear of the lathe bed. (B, Fig. 12) The forward-reverse switch (C, Fig. 12) is mounted on the top of the electric box. The motor condenser is also contained in this box.

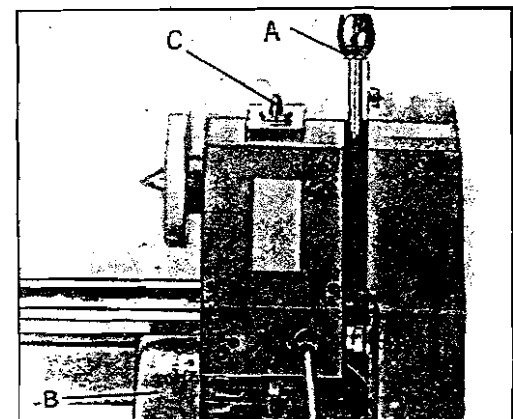
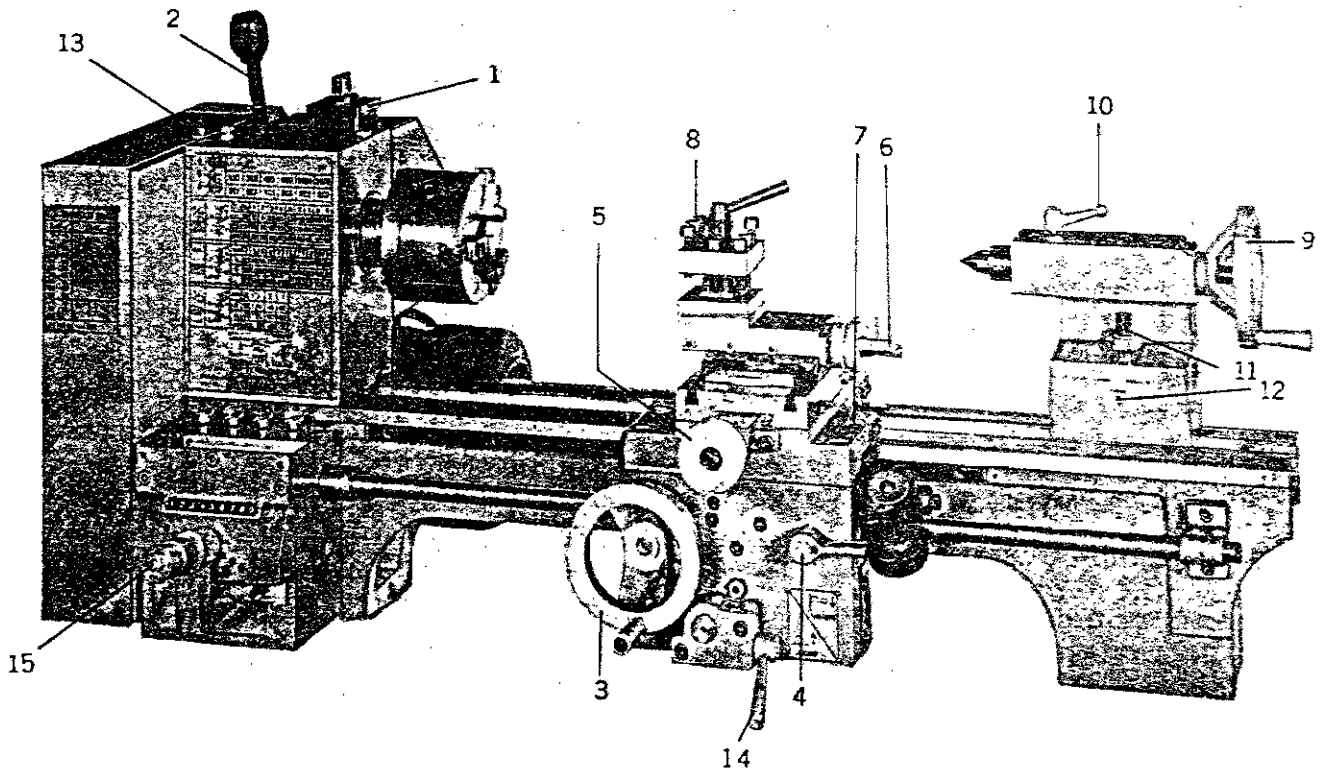

Fig. 12

Controls



1. Forward/Reverse Switch
2. V-Belt Tension Lever
3. Longitudinal Travel Handwheel
4. Half-Nut Lever
5. Cross Slide Handwheel
6. Top Slide Handwheel
7. Longitudinal Lock Screw
8. Tool Post

9. Tailstock Spindle Handwheel
10. Tailstock Spindle Clamping Lever
11. Tailstock Locking Screw
12. Tailstock Off-Set Adjustment
13. End Gear Cover Lock Screw
14. Automatic Feed Lever
15. Gear Box Quick Change Lever

Operation

Tool Set-Up

The cutting angle is correct when the cutting edge is in line with the center axis of the work piece. The correct height of the tool can be achieved by comparing the tool point with the point of the center mounted in the tailstock. The correct tool height can be obtained by using shims under the tool. (Fig. 13)

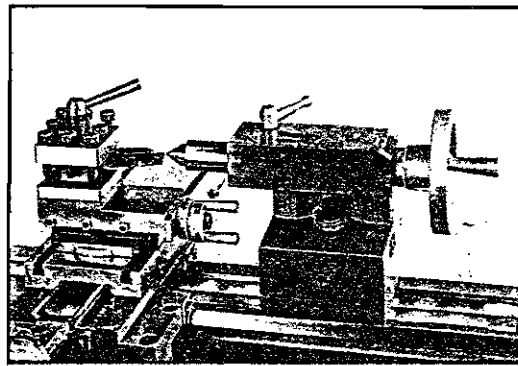

Fig. 13

When turning, the tool has a tendency to bend under pressure. For best results, tool overhang should be kept to a minimum of 3/8" or less.

Manual Turning

Apron travel, cross travel, and top slide handwheels can be operated for longitudinal or cross feeding. (Fig. 14)

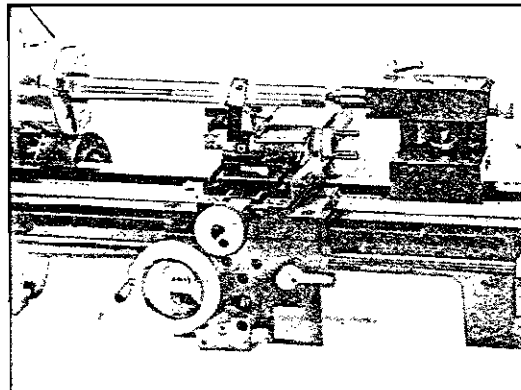

Fig. 14

Longitudinal Turning with Auto-Feed

Three automatic feeds are available. (Fast = 0.011"/rev., medium = 0.007"/rev., slow = 0.005"/rev.) These can be set by altering the gear wheel combinations. (See table - Fig. 15)

	Lever	9	1	9	1
	a	28	28	45	45
	b	60	60	60	60
	Feed	.005	.007	.007	.011

Fig. 15

By moving lever (A, Fig. 16) upward, the automatic feed is engaged.

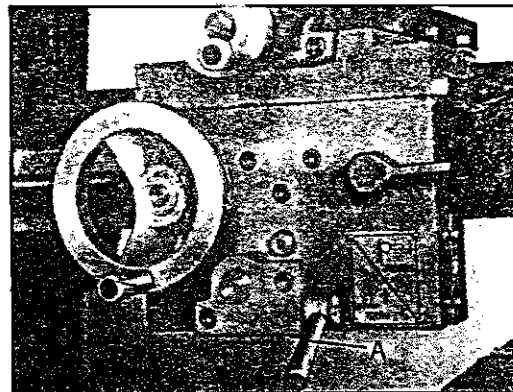

Fig. 16

Taper Turning Using Tailstock Off-Set

Work to a side angle of 5° can be turned by off-setting the tailstock. The angle depends on the length of the workpiece. (Fig. 17)

To off-set the tailstock, loosen locking screw (1, Fig. 17). Loosen the front adjusting screw (2) and take up the same amount by tightening the rear adjusting screw (3) until the desired taper has been reached. Tighten the front screw to lock the tailstock in position. The workpiece must be held between to centers and driven by a face plate and driver dog.

After taper turning, the tailstock should be returned to it's original position. The zero position of the tailstock is checked by turning a test piece with constant adjustment until the piece is absolutely true.

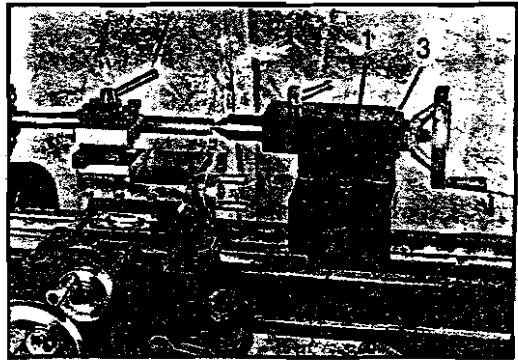

Fig. 17

Taper Turning by Setting the Top Slide

By angling the top slide, tapers may be turned. (Fig. 18)
To rotate the top slide:

Loosen two screws (1, Fig. 18), top slide can then be rotated. A graduated scale permits accurate adjustment of the top slide. This method can only be used for short tapers.

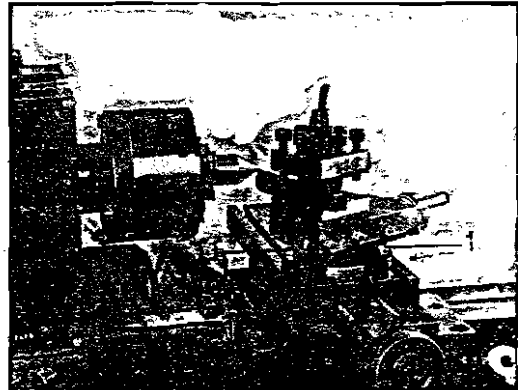

Fig. 18

Turning Between Centers

For turning between centers, it is necessary to remove the chuck from the spindle. Fit the MT-3 center into the spindle nose and the MT-2 center into the tailstock. Mount the workpiece fitted with the driver dog between the centers. The driver is driven by a catch plate or face plate. (Fig. 19)

Note: Always use a small amount of grease on the tailstock center to prevent center tip from overheating.

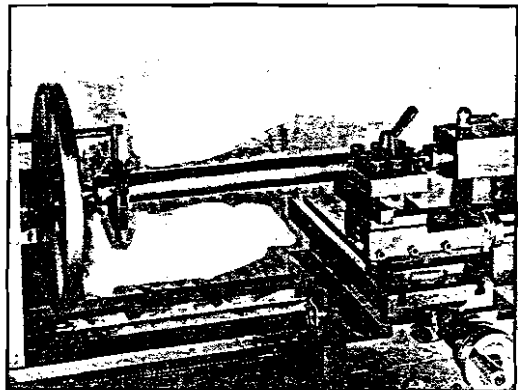

Fig. 19

Thread Cutting

As indicated on the threading charts below, several different threads can be cut using the proper combination of gears and settings. When cutting inch threads, the half nut and threading dial (figures 20 and 21) are used to thread in a conventional manner. The thread dial charts specifies at which point a thread can be entered using the threading dial.

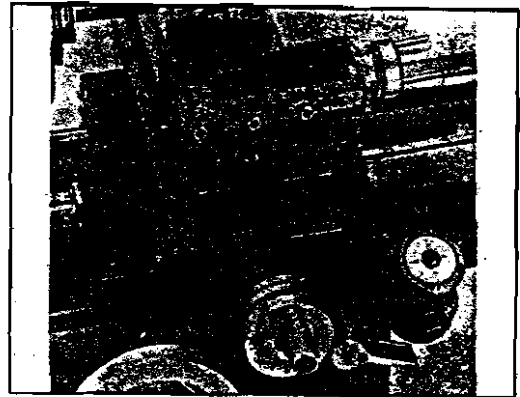

Fig. 20

Metric Thread Cutting

The only difference in metric thread cutting is the half nut must be engaged during the entire threading process. The thread dial cannot be utilized.

Set the machine up for the desired thread pitch (according to the metric threading chart below). Start the machine and engage the half nut. When the tool reaches the part, it will cut the initial threading pass. When the tool reaches the end of the cut, stop the machine by turning the motor off and at the same time back the tool out of the part so that it clears the thread. Do not disengage the half nut lever. Reverse the motor direction to allow the cutting tool to traverse back to the starting point. Repeat these steps until you have obtained the desired results.

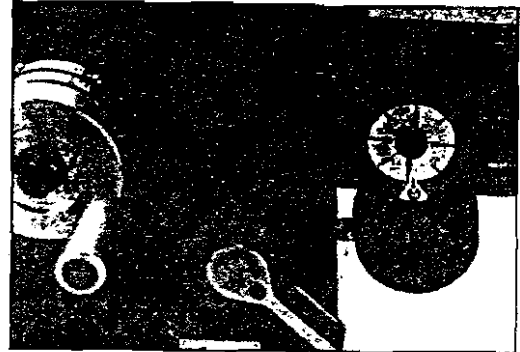

Fig. 21

Example of Gear Set-Up to Cut 10 T.P.I. (Fig. 22)

1. Loosen screw (1, Fig. 22)
2. Loosen bolt (2). Remove washers (3) and gear (6).
3. Loosen bolts (7) to allow movement in the center gear position.
4. Loosen nuts (5). Remove washer (4) and gear (8).

Reassemble as follows:

1. Install 30 tooth gear in position (6) with bushings, washer, and bolt.
2. Install 60 tooth gear in position (8).
3. Center 127 tooth gear remains in place.
4. Adjust gear to mesh with upper and lower gear and tighten bolts (7).

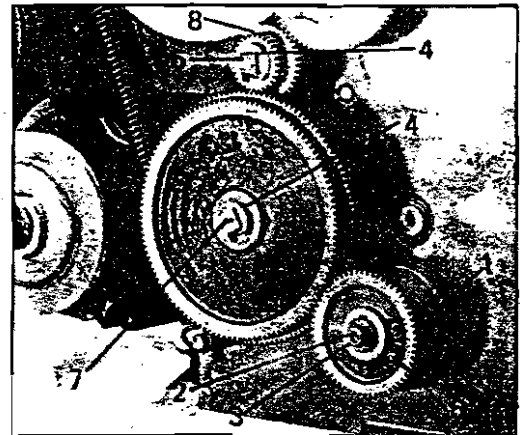

Fig. 22

Slip Clutch

To avoid overloading the drive, a safety slip clutch is fitted in the 130 RPM position. Overloading the drive (rattling noise) means the depth of cut is too deep and should be reduced.

		INCH													THREAD DIAL	
		1	2	3	4	5	6	7	8	9	T.P.I.	DIAL				
	a	60	30	8	9	9.5	10	11	11.5	12	13	14	8	10		
	b	30	30	18	18	19	20	22	23	24	26	28	16	18		
		30	60	32	36	38	40	44	46	48	52	56	20	22		
														24	26	
		METRIC														
		Lever	7	1	1	4	7	1	1	1	7	1	1	40	44	
	a	30	28	30	30	30	30	30	42	60	60	60	40	44		
	b	60	60	60	45	30	36	30	36	30	36	30	46	46		
														52	56	
														57	58	
			0.5	0.7	0.75	0.8	1	1.25	1.5	1.75	2	2.5	3	71	1.3	
														19	5.7	
														25	2.5	

Lathe Accessories

Three Jaw Universal Lathe Chuck

Using this universal chuck, round, triangular, square, hexagonal, octagonal, and twelve-cornered stock may be clamped. (Fig. 23)

Note: new lathes have very tight fitting jaws. This is necessary to ensure accurate clamping and long service life. With repeated opening and closing, the jaws adjust automatically and their operation becomes progressively smoother.

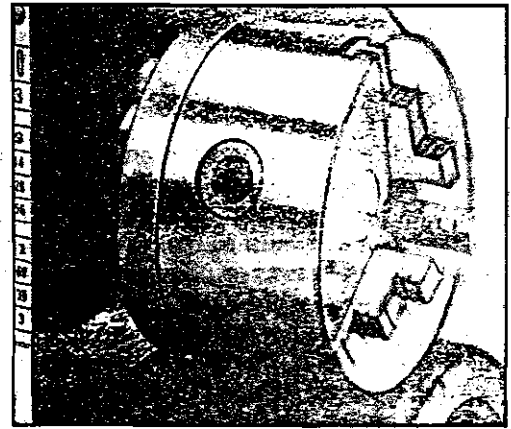

Fig. 23

Four Jaw Independent Lathe Chuck

This special chuck has four independently adjustable chuck jaws. These permit the holding of asymmetrical pieces and enable the accurate set-up of cylindrical pieces. (Fig. 24)

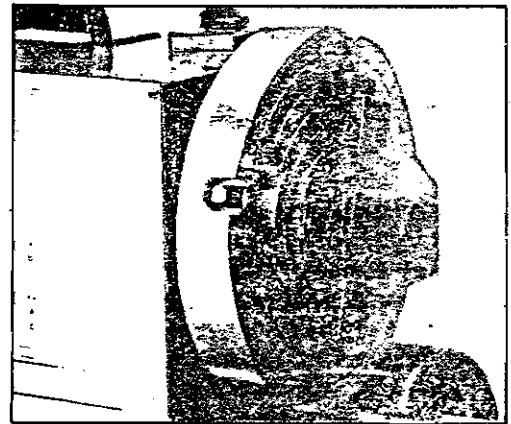

Fig. 24

Drill Chuck (Optional)

Use the drill chuck to hold centering drills and twist drills in the tailstock. (Fig. 25)

Morse Taper Arbor (Optional)

An arbor is necessary for mounting the drill chuck in the tailstock. It has a No. 2 Morse taper. (Fig. 25)

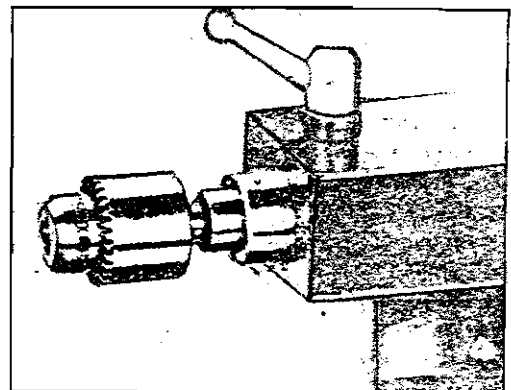

Fig. 25

Live Center (Optional)

The live center is mounted in ball bearings. Its use is highly recommended for turning at speeds in excess of 600 RPM. (Fig. 26)

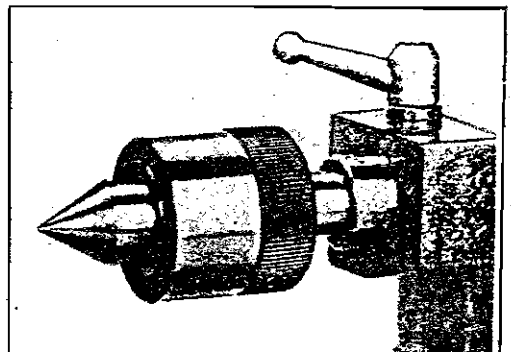

Fig. 26

Steady Rest

The steady rest serves as a support for shafts on the free tailstock end. For many operations, the tailstock cannot be used as it obstructs the turning tool or drilling tool, and therefore, must be removed from the machine. The steady rest, which functions as an end support, ensures chatter-free operation. The steady rest is mounted on the bedways and is secured from below with a locking plate. The sliding fingers require continuous lubrication at the contact points to prevent premature wear. (Fig. 27)

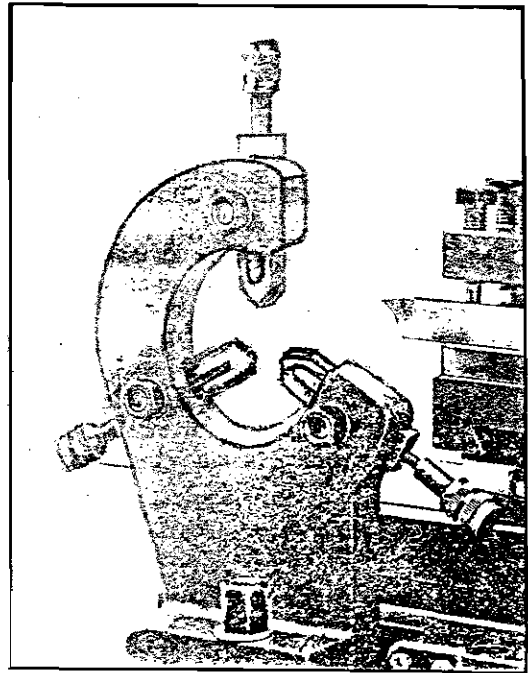

Fig. 27

Setting the Steady Rest

1. Loosen three hex nuts (1, Fig. 28)
2. Loosen knurled screw (3, Fig. 28) and open the sliding fingers (2, Fig. 28) until the steady rest can be moved with its fingers around the workpiece. secure the steady rest in position.
3. Tighten knurled screws so that fingers are snug but not tight against the workpiece. Tighten three nuts (1, Fig. 28). Lubricate the sliding points with machine oil.
4. When, after prolonged operation, the jaws show wear, the tips of the fingers may be filed or remilled.

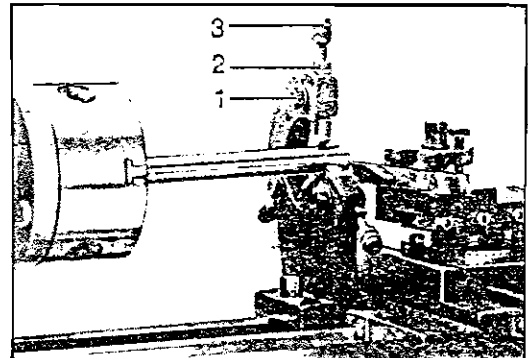

Fig. 28

Follow Rest

The follow rest is mounted on the saddle and follows the movement of the turning tool. Only two sliding fingers are required. The place of the third finger is taken by the turning tool. The follow rest is used for turning operations on long, slender workpieces. It prevents flexing of the workpiece under pressure from the turning tool. (Fig. 29)

Set the fingers snug to the workpiece but not overly tight. Lubricate the fingers during operation to prevent premature wear.

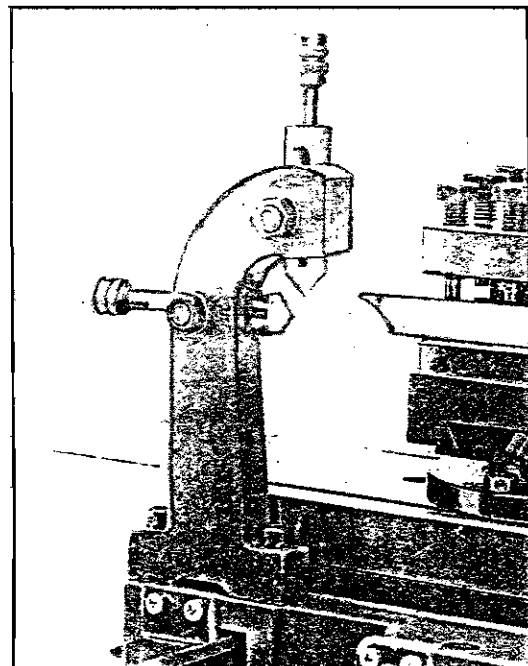

Fig. 29

Four Way Tool Post

The four way tool post is mounted on the top slide and allows four tools to be clamped. Loosen the center clamp handle to rotate any of the four tools into position. (Fig. 30)

Use a minimum of two clamping screws when installing a cutting tool.

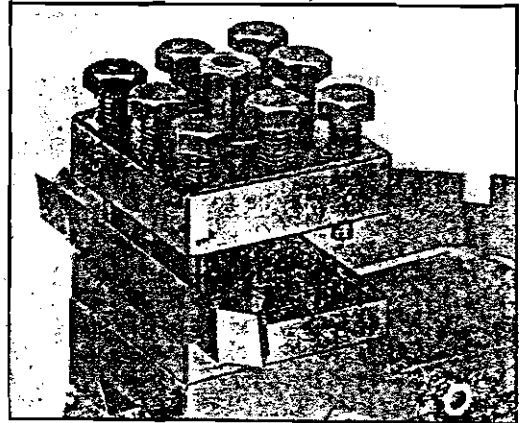

Fig. 30

Change Gears

There are six gears with different number of teeth, (28, 30, 36, 42, 45, and 80). They can be combined for different speeds and feeds as required. See chart on headstock. (Fig. 31)

Note: The 80 tooth plastic gear is fitted to the machine as a safety gear. Replace with a new one if damaged.

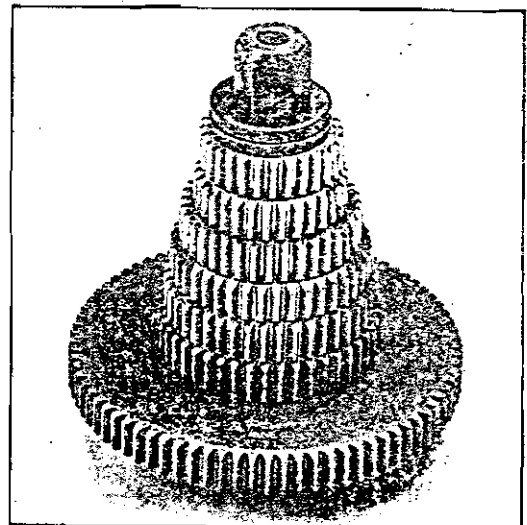

Fig. 31

Bearings and Slide Adjustment

Adjustment of the Main spindle Bearings

The main spindle bearings are adjusted at the factory. If end play becomes evident after considerable use, the bearings may be adjusted.

Loosen set screw (1, Fig. 32) in the slotted nut (2, Fig. 32) on the back of the spindle. Tighten slotted nut until all end play is taken up. The spindle should still revolve freely. Caution: excessive tightening or preloading will damaged the bearings. Tighten set screw (1, Fig. 32)

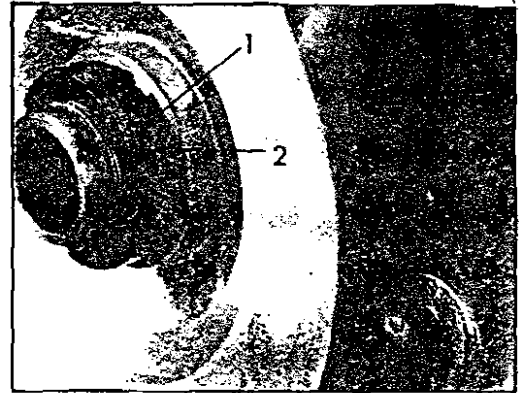

Fig. 32

Adjustment of Cross and Top Slide

Each slide is fitted with a gib strip and can be adjusted with screws (1, Fig. 33) fitted with lock nuts (2, Fig. 33). Loosen the lock nuts and tighten the set screws until slide moves freely without play. Tighten lock nuts to retain adjustment.

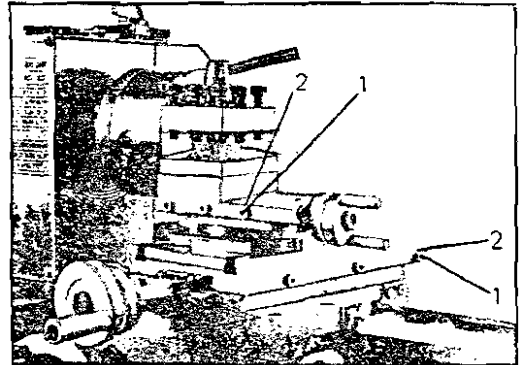

Fig. 33

Adjustment of Compound Feed Screw End Float

To adjust the slides on the saddle:
Loosen screw (1, Fig. 34) and lock nut (2, Fig. 34).
Adjust the nut until all play has been taken up. Lock the nut (2) with the screw (1).

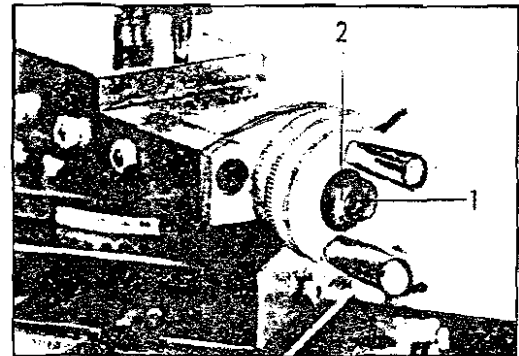

Fig. 34

Cross Slide Screw

Remove the compound slide (Fig. 35) and adjust screw (1, Fig. 35) until the backlash between the spindle and the nut is eliminated.

For operator convenience, the compound may be located in two positions on the cross slide.

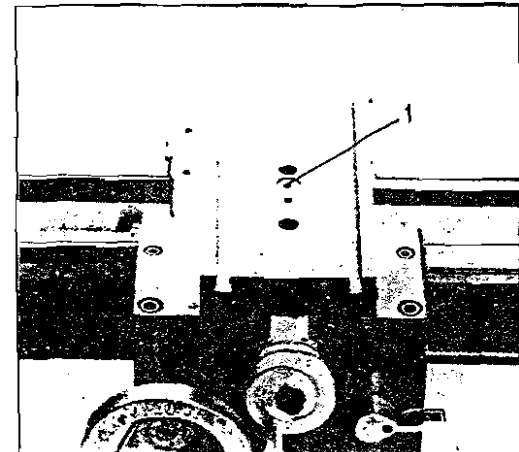

Fig. 35

Compound Slide Spindle Backlash Adjustment

Remove two screws holding the spindle bracket in position and unscrew the spindle. Adjust the screw ring (1, Fig. 36) until all backlash has been eliminated.

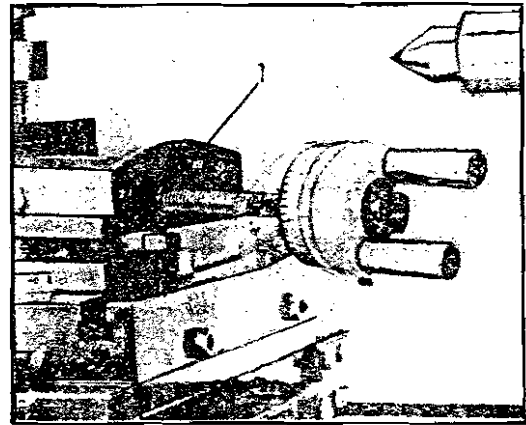

Fig. 36

Adjustment of Half-Nut Guide

Loosen two nuts (1, Fig. 37) on the right side of the apron and adjust the control screws (2, Fig. 37) until both half nuts move freely without play. Tighten both nuts.

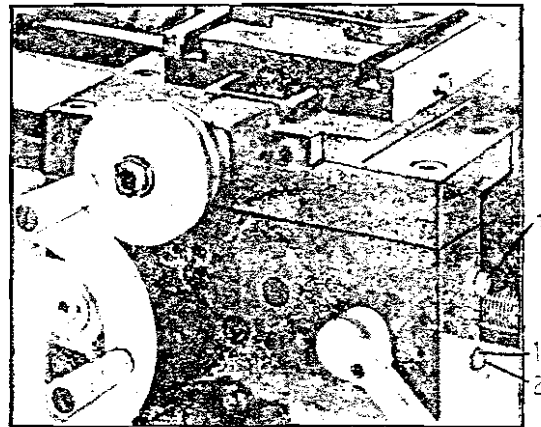

Fig. 37

Replacing the Shear Pin in the Leadscrew

If the shear pin breaks, it must be replaced. (Fig. 38) To knock out the broken pin, the hex head screw must be loosened and the pinion removed. Take off the sleeve and remove the broken pin from the sleeve and the leadscrew. Replace the sleeve, line up the holes, fit the new pin, and assemble.

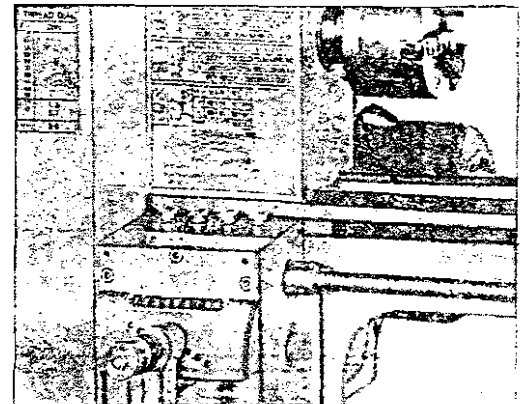

Fig. 38

Replacing the V-Belt

Loosen the screw on the top of the headstock and open the cover. (Fig. 39)

Remove tension on the V-belt by pulling handle toward front of the machine. (Fig. 39) Remove belt from the pulleys and replace with new belt. Move lever toward motor to tension belt. (Fig. 40) Close cover and secure with screw.

Caution: to avoid breaking the belt, move the tension lever towards the front of the machine before starting. (Fig. 41)

Electrical Connections

The BD-920N Bench Lathe is rated at 3/4 HP, 1 Ph., 60 HZ, 115V only. Confirm the power at the location is the same as the rating of the lathe before plugging the lathe in. Do not attempt to run this lathe on any other type of power.

The lathe must be properly grounded. The lathe is designed to be used with an outlet as in Fig. 42. If this type of outlet is not readily available, an adapter (as in Fig. 43) may be used temporarily until a qualified electrician can install a grounded outlet. Make sure the grounding tab on the adapter is secured to the cover plate screw.

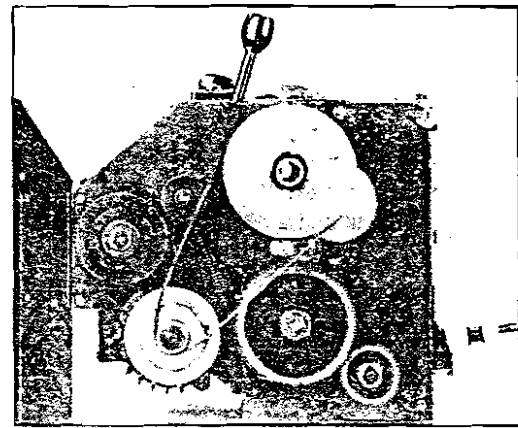

Fig. 39

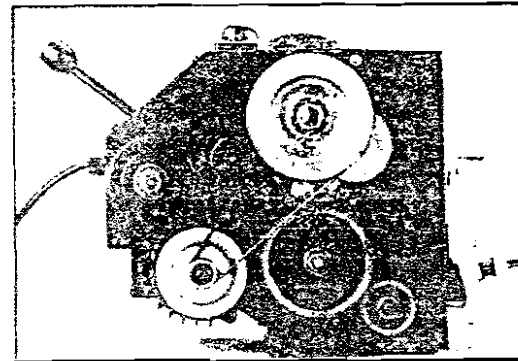

Fig. 40

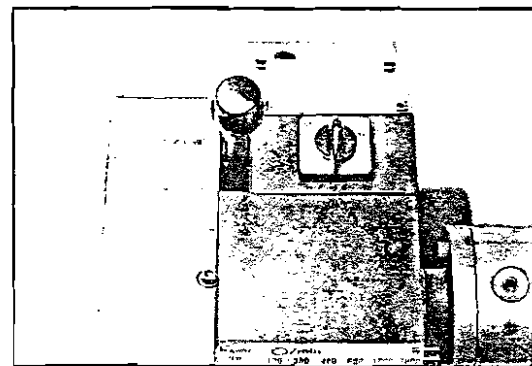

Fig. 41

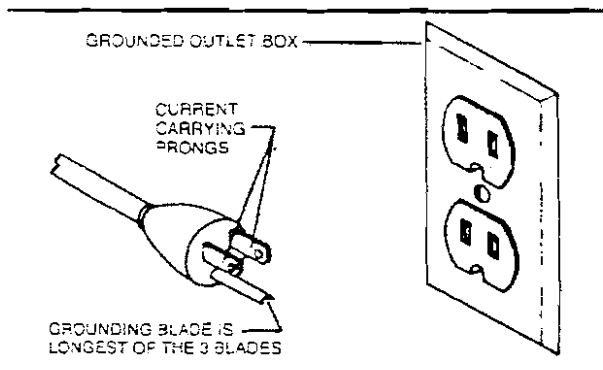

Fig. 42

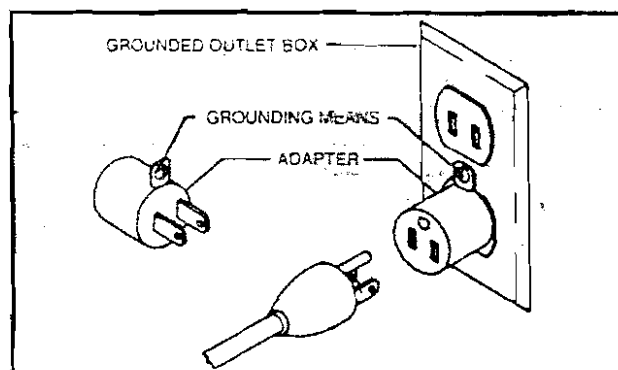

Fig. 43

Lubrication Schedule

Note: lubricate all locations daily.

Grease refers to #2 tube grease.

Oil refers to 20W machine oil.

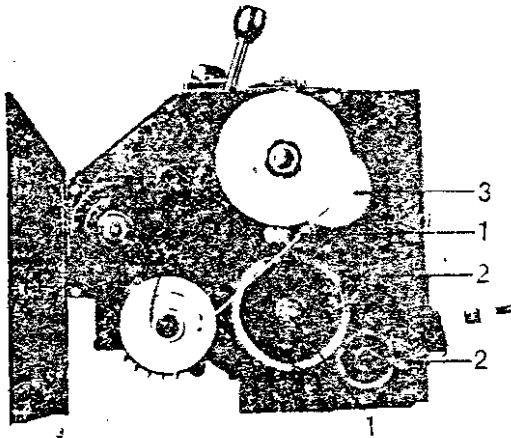

1. 1-2 squirts oil into oil ball on gear hub.
2. Grease teeth of feed and change gears.
1-2 squirts oil into oil ball on gear hub.
3. Lightly coat gear teeth with oil.
1-2 squirts oil into oil ball on gear hub.
4. Wipe bedways clean and coat lightly with oil.
5. Grease rack over complete length.
6. Clean and oil leadscrew over complete length.
7. 1-2 squirts oil into oil ball on leadscrew bracket.
8. Lightly coat screw and guides of top slide with oil.
9. 1-2 squirts oil into oil ball on top of tailstock body.
10. 1-2 squirts oil into oil ball on top of carriage.
11. 1-2 squirts oil into four oil reservoirs on gear box.
12. 1-2 squirts oil into hub for feed lever.
13. 1-2 squirts oil into two oil balls on apron front.

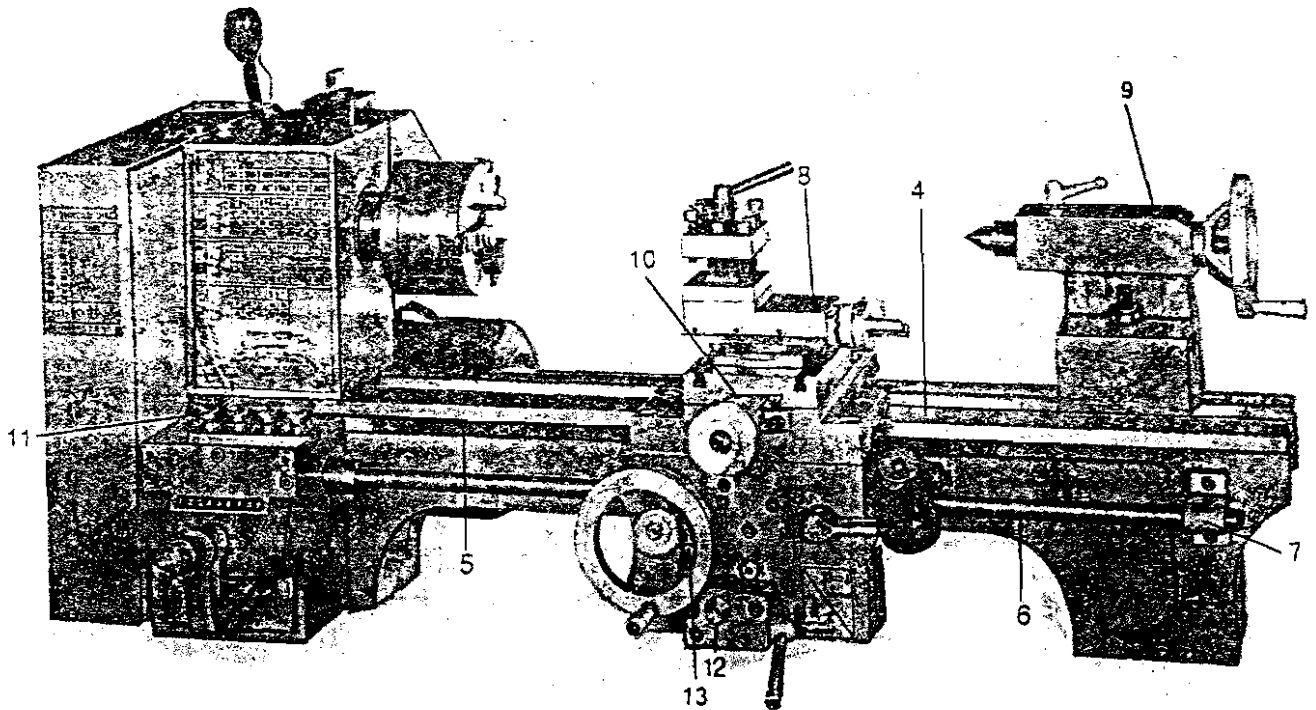

Headstock Assembly

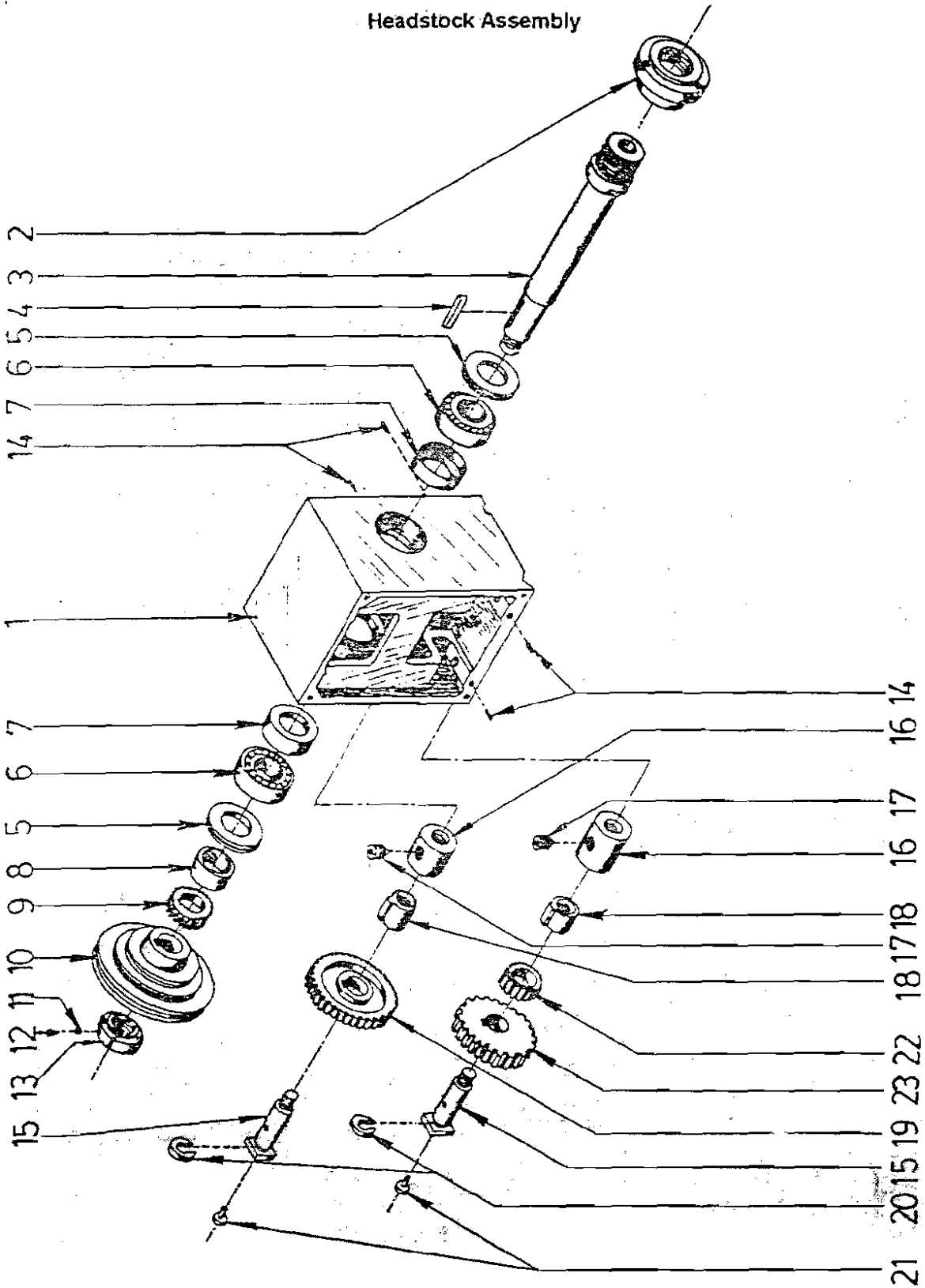

Parts List For the BD-920N Bench Lathe

Please Order by Part Number Only

Headstock Assembly

Index No.	Part No.	Description	Size	Qty.
1	1002	Headstock Casting		1
2	1006	Flange Joint		1
3	1004	Spindle		1
4	BD920N-H04	Key		1
5	1005	Gasket		2
6	BD920N-H06	Ball Bearing		2
7	1003	Cover		1
8	1007	Spacing Ring		1
9	1011	Gear	40T	1
10	1008	Pulley		1
11	1010	Bushing		1
12	TS-152102	Set Screw	M4x6	4
13	1012	Nut	M28	1
14	TS-152104	Set Screw	M4x10	4
15	1017	Shaft		2
16	1015	Spacing Ring		2
17	TS-152102	Set Screw	M4x6	1
18	1016	Bushing		2
19	1014	Gear (plastic)	80T	1
20	1013	Washer		2
21	BD920N-H21	Oil Port		2
22	1018	Gear	40T	1
23	1019	Gear	28T	1

Drive Assembly

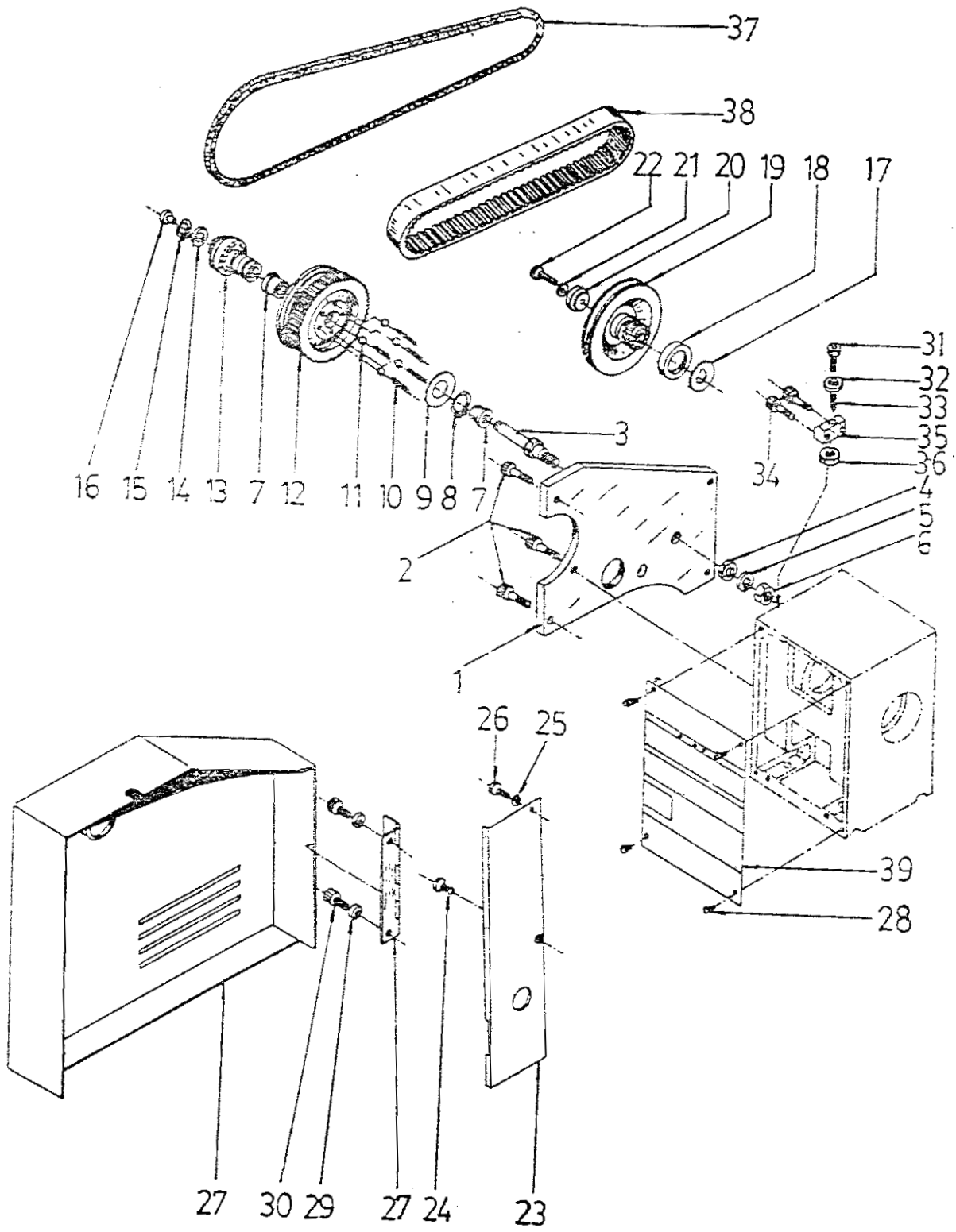

Drive Assembly

1	1044	Bracket Plate		1
2	TS-150404	Hex Socket Cap Screw	M8x20	3
3	1026	Belt Pulley Shaft		1
4	TS-1550071	Washer	M10	1
5	TS-1551071	Lock Washer	M10	1
6	TS-1540071	Hex Nut	M10	1
7	1031	Bushing		2
8	BD920N-D08	Snap Ring	25	1
9	1027	Washer		1
10	1025	Spring		5
11	BD920N-D11	Ball	5	5
12	1024	Pulley		1
13	1029	Pulley		1
14	1028	Washer		1
15	BD920N-D15	Snap Ring	12	1
16	BD920N-D16	Oil Port	6	1
17	1021	Spacer		1
18	1023	Collar		1
19	1020	Motor Pulley		1
20	1022	Washer		1
21	TS-155104	Lock Washer	M6	1
22	TS-150306	Hex Socket Cap Screw	M5x25	1
23	1049	Cover Plate		1
24	TS-150203	Hex Socket Cap Screw	M5x12	1
25	TS-1550031	Washer	M5	1
26	TS-150201	Hex Socket Cap Screw	M5x8	1
27	1045	Cover w/ Hinge		1
28	TS-150403	Hex Socket Cap Screw	M4x10	4
29	TS-1500041	Washer	M6	2
30	TS-150302	Hex Socket Cap Screw	M6x10	2
31	TS-150306	Hex Socket Cap Screw	M6x25	1
32	TS-1550041	Washer	M5	1
33	1048	Spring		1
34	TS-150305	Hex Socket Cap Screw	M6x20	2
35	1047	Clamp Block		1
36	TS-1540041	Hex Nut	M6	1
37	VB-5M710	V-Belt		1
38	VB-170xL050	Cog Belt		1
39	1001	Plate		1

Tension Roller Assembly

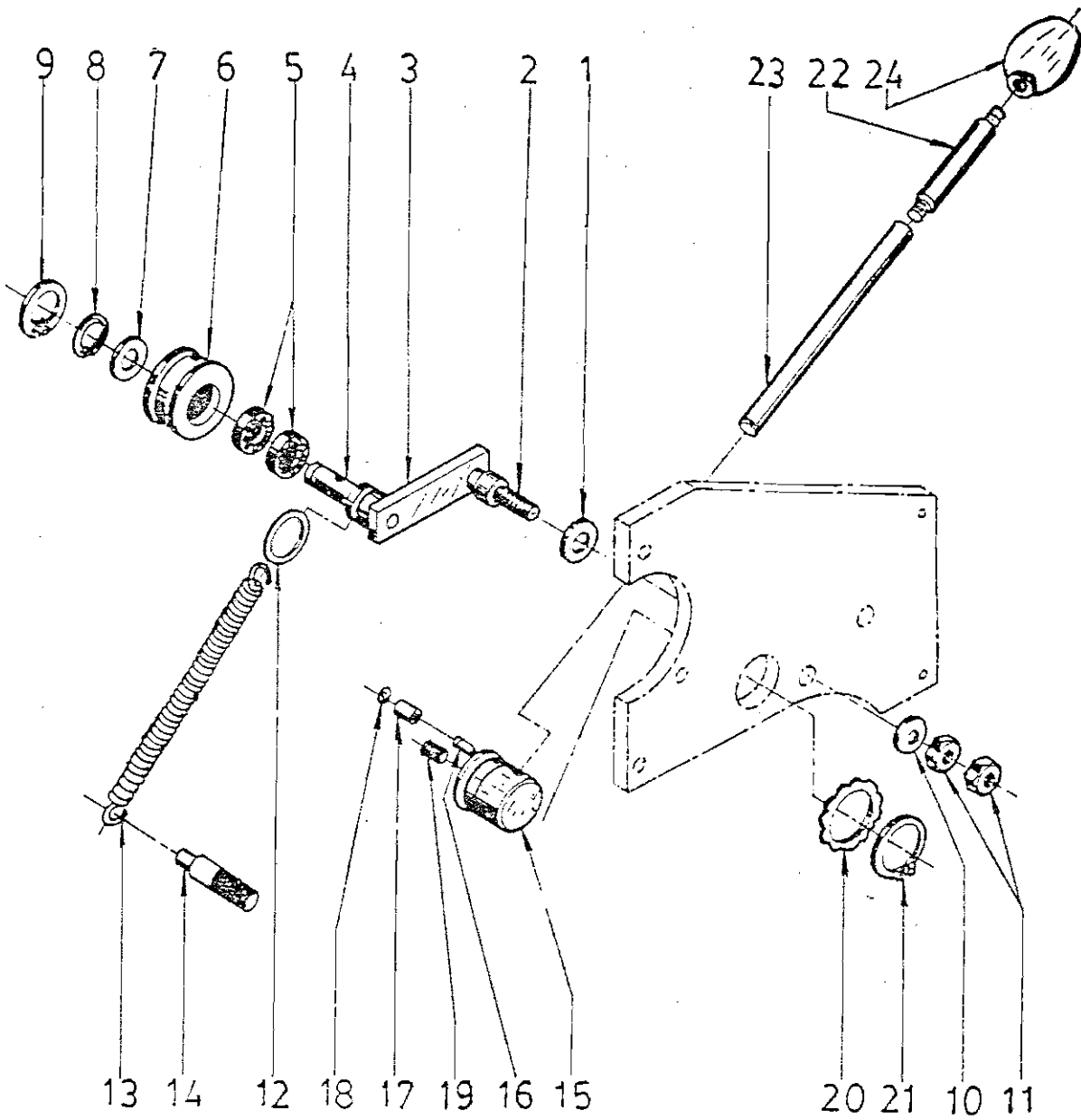

Tension Roller Assembly

1	1040N	Washer		1
2	1035	Stud Bolt		1
3	1035-1	Lever Bracket		1
4	1035-2	Lever		1
5	BD920N-TR05	Ball Bearing		2
6	1039	Roller		1
7	1038	Washer		1
8	BD920N-TR08	Snap Ring	12	1
9	BD920N-TR09	Snap Ring	28	1
10	TS-1550071	Washer	M10	1
11	TS-1540071	Nut	M10	2
12	1036	Washer		1
13	1037	Spring		1
14	1050	Stud Bolt		1
15	1032	Toggle		1
16	1051	Pin		1
17	1033	Sleeve		1
18	BD920N-TR18	Snap Ring	6	1
19	TS-152403	Set Screw	32	1
20	1034	Wave Washer		1
21	BD920N-TR21	Snap Ring		1
22	1042	Lever		1
23	1043	Lever		1
24	1044A	Knob		1

Quadrant Assembly

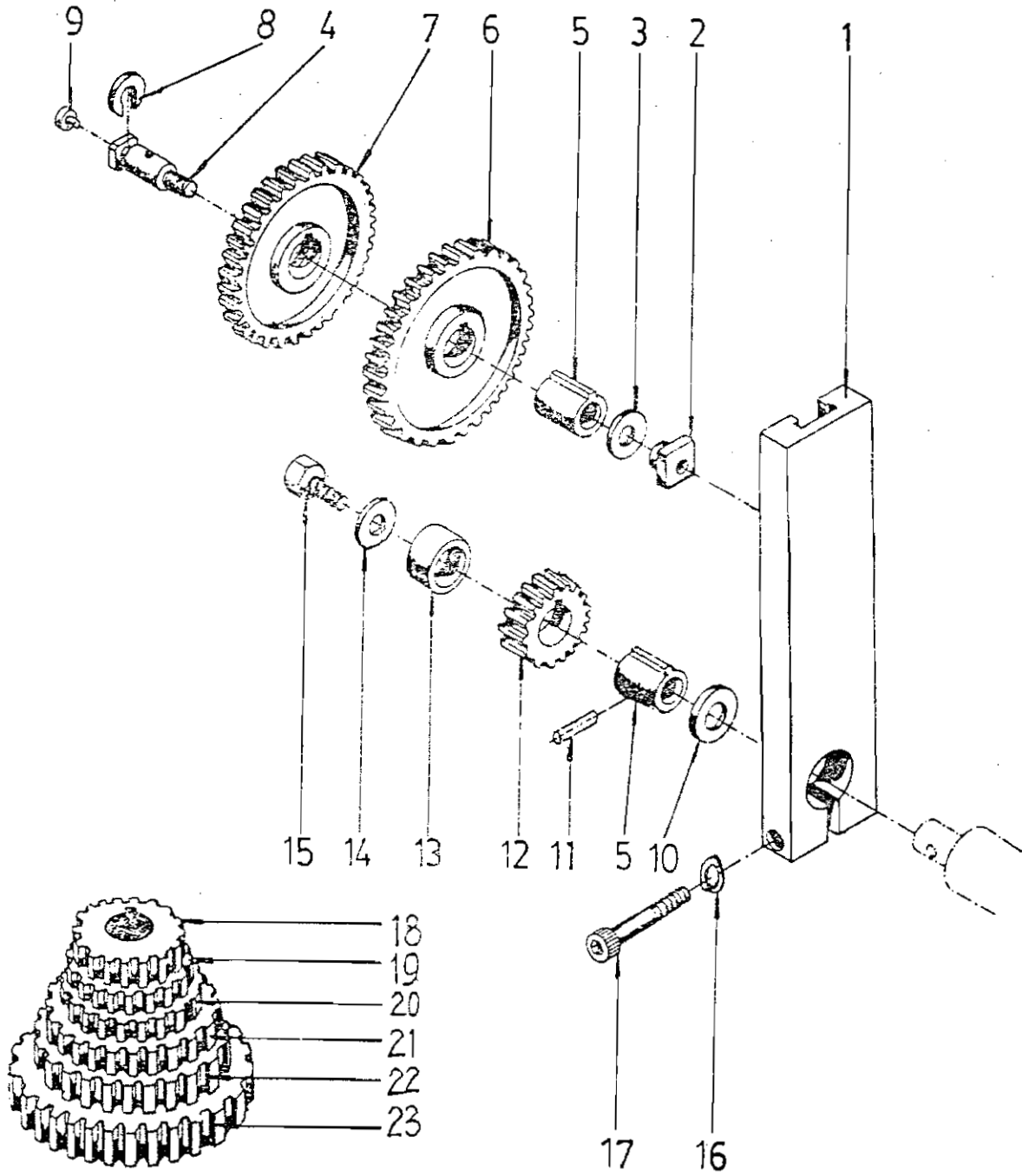

Quadrant Assembly

1.....	2003	Bracket		1
2.....	2004	T-Nut		1
3.....	TS-1550041	Washer	M6	1
4.....	2005	Shaft		1
5.....	2009	Bushing		2
6.....	2001	Gear	127T	1
7.....	2002	Gear	120T	1
8.....	2006	Washer		1
9.....	BD920N-Q09	Oil Port	6	1
10.....	TS-1550071	Washer	M10	1
11.....	BD920N-Q11	Pin	4x14	1
12.....	2007	Gear	30T	2
13.....	2008	Spacing Ring		1
14.....	TS-1550041	Washer	M6	1
15.....	TS-150302	Hex Socket Cap Screw	M6x10	1
16.....	TS-155104	Lock Washer	M6	1
17.....	TS-150308	Hex Socket Cap Screw	M6x35	1
18.....	2010	Gear	28T	1
19.....	2011	Gear	36T	1
20.....	2012	Gear	42T	1
21.....	2013	Gear	45T	1
22.....	2014	Gear	60T	1
23.....	2015	Gear	80T	1

Electrical Assembly

1.....	10002	Housing	1
2.....	BD920N-E02	Screw	4
3.....	BD920N-E03	Lock Washer	4
4.....	10001	Cover	1
5.....	BD920N-E05	Condenser Clip	1
6.....	BD920N-E06	Condenser	1
7.....	BD920N-E07	Lock Nut	1
8.....	BD920N-E08	Screw Coupling	1
9.....	BD920N-E09	Switch	1
10.....	BD920N-E10	Hex Screw	4
11.....	BD920N-E11	Motor	1
12.....	TS-155103	Lock Washer	M5	4
13.....	TS-1540031	Nut	M5	1
14.....	TS-150202	Hex Socket Cap Screw	M5x10	1

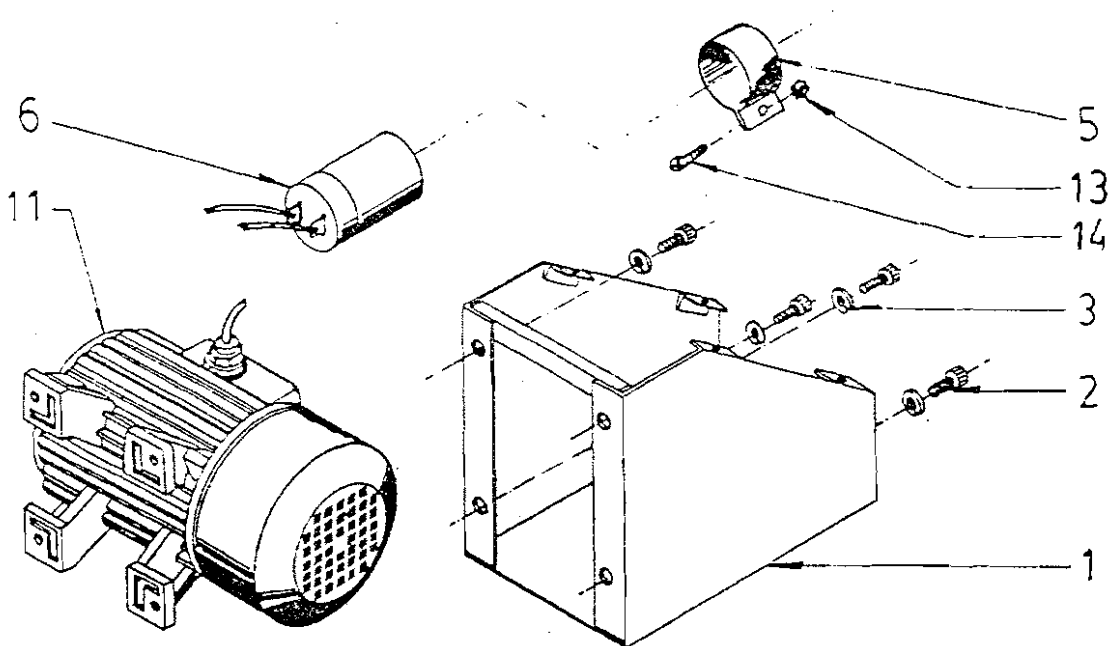
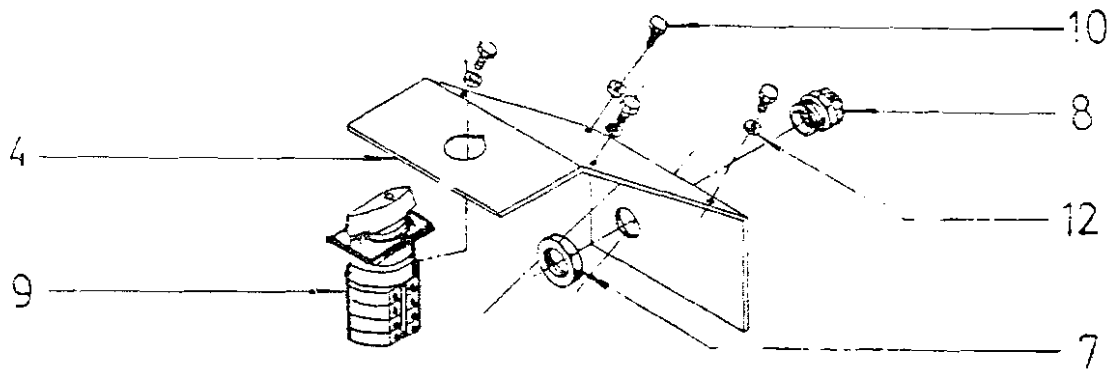

Gear Box Assembly

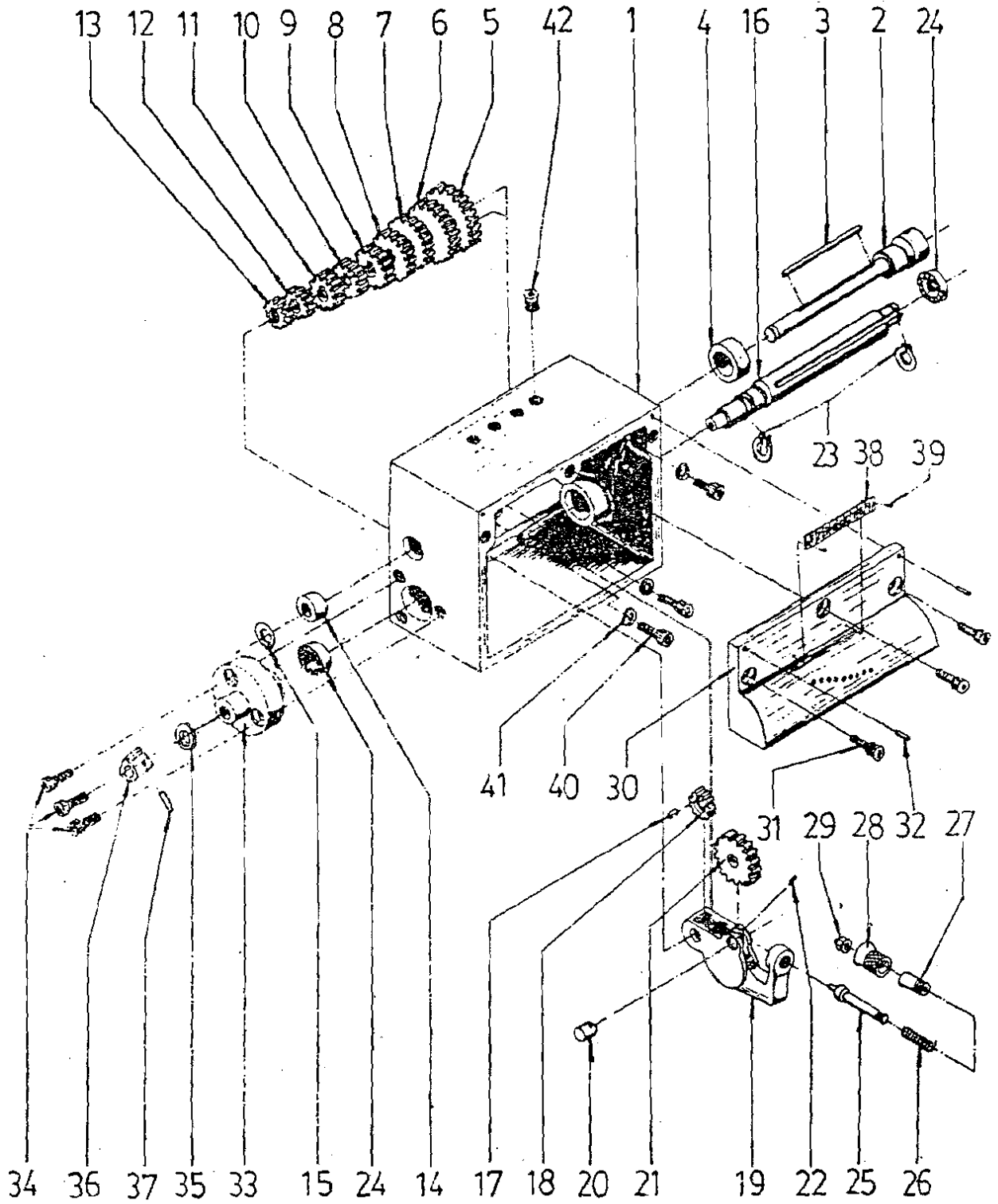

Gear Box Assembly

1.....	3001	Gear Box Casting.....	1
2.....	3009	Shaft.....	1
3.....	BD920N-GB03.....	Key.....	1
4.....	3019	Bushing.....	1
5.....	3018	Gear.....	28T..... 1
6.....	3017	Gear.....	26T..... 1
7.....	3016	Gear.....	24T..... 1
8.....	3015	Gear.....	23T..... 1
9.....	3014	Gear.....	22T..... 1
10.....	3013	Gear.....	20T..... 1
11.....	3012	Gear.....	19T..... 1
12.....	3011	Gear.....	18T..... 1
13.....	3010	Gear.....	16T..... 1
14.....	3025	Bushing.....	1
15.....	BD920N-GB15.....	Snap Ring.....	16..... 1
16.....	3020	Shaft.....	1
17.....	BD920N-GB17.....	Key.....	1
18.....	3021	Gear.....	16T..... 1
19.....	3002	Shift Arm.....	1
20.....	3007	Shaft.....	1
21.....	3023	Gear.....	36T..... 1
22.....	TS-152203.....	Set Screw.....	M5x10..... 1
23.....	BD920N-GB23.....	Snap Ring.....	15..... 2
24.....	BD920N-GB24.....	Ball Bearing.....	2
25.....	3004	Plunger.....	1
26.....	3005	Spring.....	1
27.....	3003	Bushing.....	1
28.....	3006	Handle.....	1
29.....	BD920N-GB29.....	Cap Nut.....	M10..... 1
30.....	3008	Front Cover.....	1
31.....	TS-150304.....	Hex Socket Cap Screw.....	M6x16..... 3
32.....	BD920N-GB32.....	Pin.....	6x22..... 2
33.....	3022	Bracket.....	1
34.....	TS-150302.....	Hex Socket Cap Screw.....	M6x10..... 3
35.....	TS-1550071.....	Washer.....	M10..... 1
36.....	2009	Bushing.....	1
37.....	BD920N-GB37.....	Pin.....	4x14..... 1
38.....	3026	Plate.....	1
39.....	BD920N-GB38.....	Rivet.....	2
40.....	TS-150404.....	Hex Socket Cap Screw.....	M8x20..... 3
41.....	TS-155108.....	Lock Washer.....	M8..... 3
42.....	BD920N-GB42.....	Oil Cup.....	M8x1..... 4

Apron Assembly

1.....	4006	Apron Casting	1
2.....	4034	Bracket	1
3.....	4033	Worm	1
4.....	BD920N-A04	Key	1
5.....	TS-150306	Hex Socket Cap Screw	M6x25 3
6.....	7003	Feed Screw	1
7.....	TS-1540021	Nut	1
8.....	TS-152105	Set Screw	M4x12 2
9.....	BD920N-A09	Steel Ball	5 2
10.....	4021	Spring	1
11.....	4022	Handle	1
12.....	TS-152301	Set Screw	M6x6 2
13.....	4005	Washer	3
14.....	BD920N-A14	Flat Head Screw	M6x8 3
15.....	4008	Gear	12T 1
16.....	BD920N-A16	Spring Pin	4x30 1
17.....	4007	Gear	43T 1
18.....	4015	Handle	1
19.....	4014	Gear	13T 1
20.....	4013	Bracket	1
21.....	4025	Spring	1
22.....	TS-152104	Set Screw	M4x10 1
23.....	TS-150307	Hex Socket Cap Screw	M6x30 2
24.....	4011	Gear	43T 1
25.....	4009	Shaft	1
26.....	BD920N-A26	Key	4x5 1
27.....	4010	Gear	41T 1
28.....	BD920N-A28	Ring	14 1
29.....	BD920N-A29	Oil Port	6 2
30.....	4004	Gear	17T 1
31.....	4003	Hand Wheel	1
32.....	BD920N-A32	Spring Pin	4x25 1
33.....	4002	Screw	1
34.....	4001	Handle	1
35.....	4018	Label	1

Apron Assembly (cont'd)

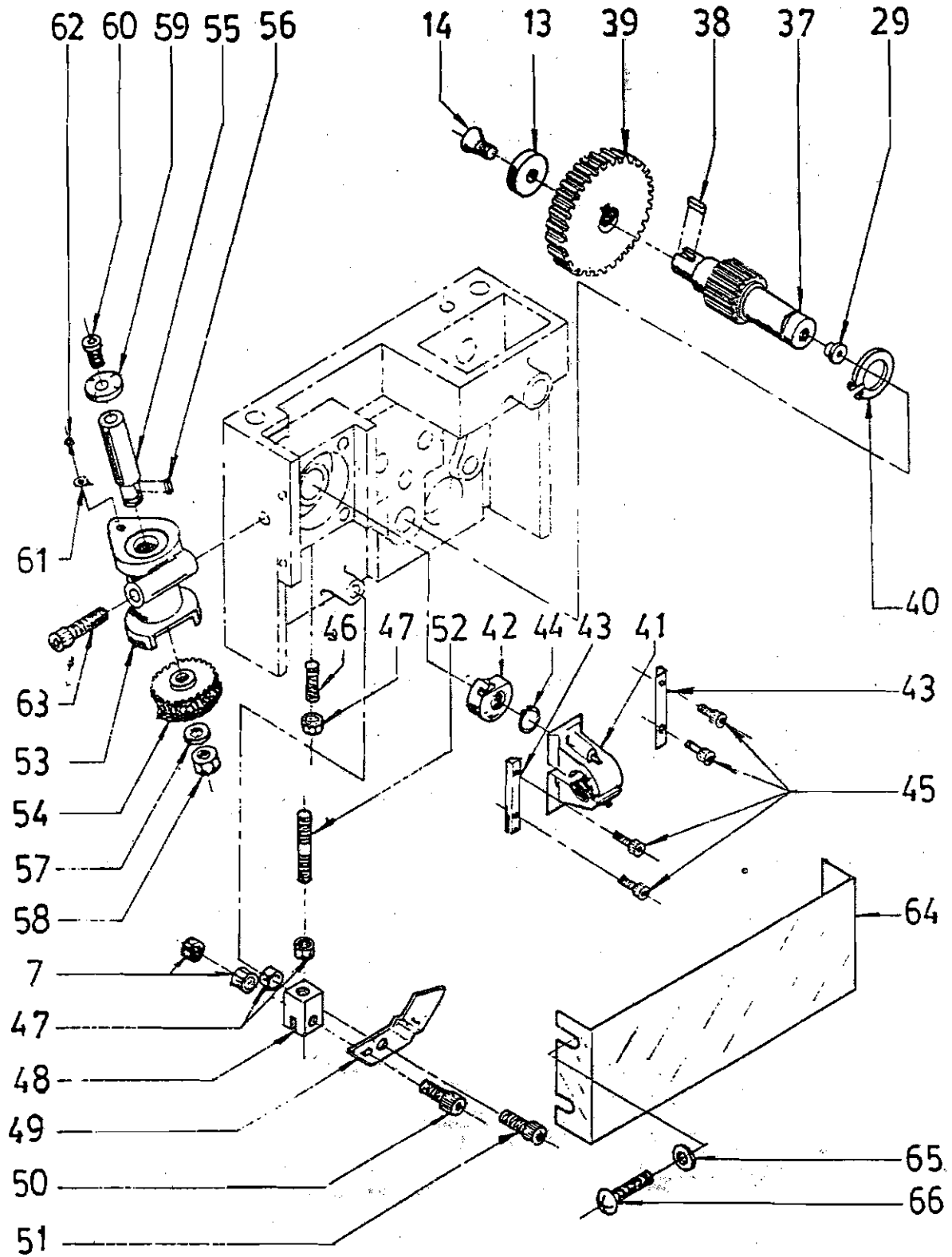

Apron Assembly (cont'd)

37.....	4016	Gear.....	18T.....	1
38.....	BD920N-A38	Key.....	4x11.....	1
39.....	4012	Worm Gear.....	42T.....	1
40.....	BD920N-A40	Ring.....	12.....	1
41.....	4017	Half Nut.....		1
42.....	4019	Locking Cam.....		1
43.....	4020	Guide.....		1
44.....	BD920N-A44	Ring.....	8.....	1
45.....	TS-150105	Hex Socket Cap Screw.....	M4x16.....	4
46.....	BD920N-A46	Set Screw.....	M5x25.....	1
47.....	TS-1540031	Hex Nut.....	M5.....	3
48.....	4030	Control Block.....		1
49.....	4032	Joint Plate.....		1
50.....	TS-150106	Hex Socket Cap Screw.....	M4x20.....	1
51.....	TS-150204	Hex Socket Cap Screw.....	M5x16.....	1
52.....	4031	Screw.....		1
53.....	4036	Thread Dial Body.....		1
54.....	4029	Worm Gear.....	64T.....	1
55.....	4028	Shaft.....		1
56.....	BD920N-A56	Key.....	3x10.....	1
57.....	TS-155006	Lock Washer.....	M8.....	1
58.....	TS-154006	Hex Nut.....	M8.....	1
59.....	4027	Dial.....		1
60.....	BD920N-A60	Screw.....	M6x60.....	1
61.....	4024	Pointer.....		1
62.....	BD920N-A62	Rivet.....	2x5.....	1
63.....	TS-150313	Hex Socket Cap Screw.....	M6x60.....	1
64.....	4023	Apron Cover.....		1
65.....	TS-155002	Washer.....	M4.....	4
66.....	TS-1532021	Pan Head Machine Screw.....	M4x8.....	4

Saddle and Cross Slide Assembly

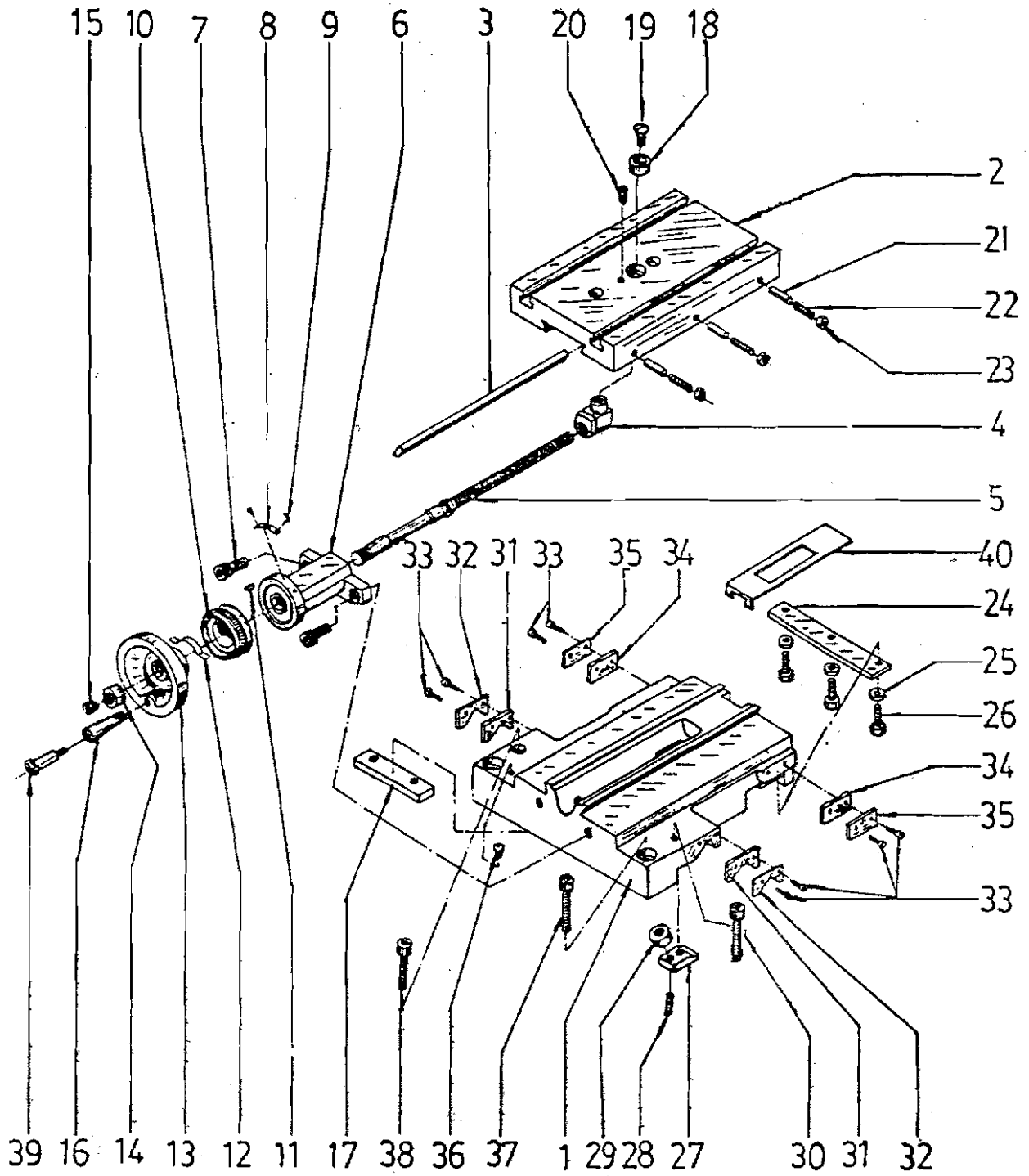

Saddle and Cross Slide Assembly

1.....	5005	Saddle.....		1
2.....	5006	Cross Slide.....		1
3.....	5002	Gib.....		1
4.....	5036	Nut.....		1
5.....	5018	Lead Screw.....		1
6.....	5019	Bracket.....		1
7.....	TS-150304	Hex Socket Cap Screw.....	M5x16	2
8.....	5026	Plate.....		1
9.....	BD920N-CS09	Rivet.....	2x5	2
10.....	5020	Graduated Ring.....		1
11.....	BD920N-CS11	Key.....	3x13	1
12.....	5023	Spring.....		1
13.....	5021	Hand Wheel.....		1
14.....	5022	Hex Nut.....		1
15.....	BD920N-CS15	Set Screw.....	M8x6	1
16.....	5025	Handle.....		1
17.....	5003	Slide Block.....		1
18.....	5037	Bushing.....		1
19.....	TS-1534041	Flat Head Screw.....	M6x12	1
20.....	TS-1521031	Set Screw.....	M4x8	1
21.....	5001	Pin.....		3
22.....	TS-152105	Set Screw.....	M4x12	3
23.....	TS-154002	Nut.....	M4	3
24.....	5016	Slide Block.....		1
25.....	TS-1550041	Washer.....	M6	3
26.....	TS-150304	Hex Socket Cap Screw.....	M6x16	3
27.....	5017	Clip.....		1
28.....	TS-152306	Set Screw.....	M6x20	1
29.....	TS-1540041	Nut.....	M6	1
30.....	TS-150306	Hex Socket Cap Screw.....	M6x25	1
31.....	5042	Way Cover.....		2
32.....	5041	Cover Mount.....		2
33.....	TS-1532012	Pan Head Screw.....	M4x6	8
34.....	5040	Way Cover.....		2
35.....	5039	Cover Mount.....		2
36.....	BD920N-CS36	Oil Port.....	6	1
37.....	TS-150406	Hex Socket Cap Screw.....	M8x30	2
38.....	TS-150306	Hex Socket Cap Screw.....	M6x25	2
39.....	5024	Handle Screw.....		1
40.....	5038	Cover Mount.....		1

Top Slide Assembly

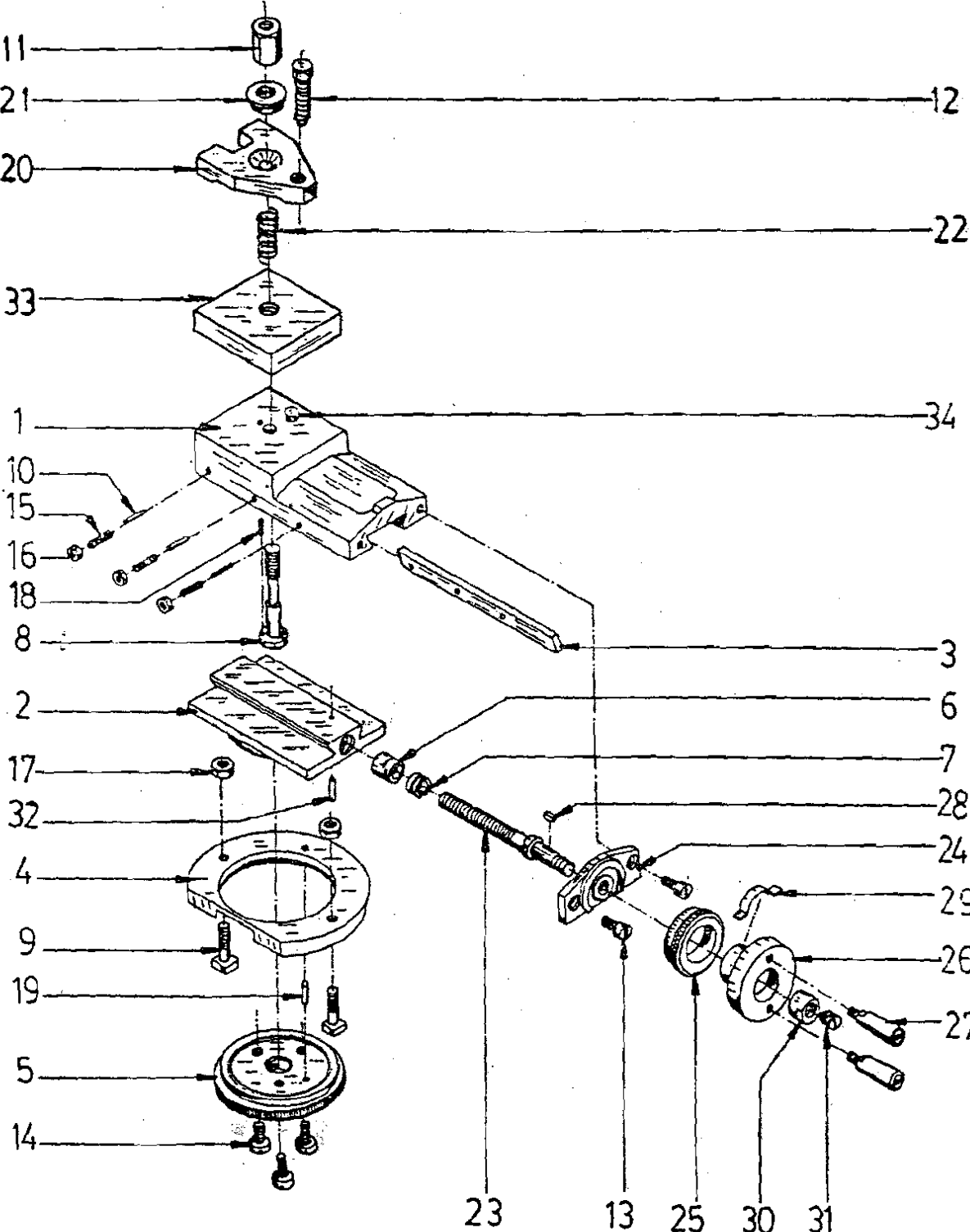

Top Slide Assembly

1	5011	Longitudinal Slide		1
2	5010	Swivel Base		1
3	5028	Gib		1
4	5008	Clamping Ring		1
5	5009	Micrometer Pan		1
6	5013	Lead Screw Nut		1
7	5014	Adjusting Screw		1
8	5033	Screw		1
9	5007	T-Screw		2
10	5027	Pin		3
11	5032	Nut		1
12	TS-1490051	Hex Cap Bolt	M8x30	1
13	TS-150202	Hex Socket Cap Screw	M5x10	2
14	BD920N-TS14	Flat Head Screw	M6x12	3
15	TS-152104	Set Screw	M4x10	3
16	TS-1550021	Nut	M4	3
17	TS-1550041	Nut	M6	2
18	BD920N-TS18	Lock Pin	3x8	1
19	BD920N-TS19	Lock Pin	3x14	1
20	5030	Tool Clamp		1
21	BD920N-TS21	Washer	8	1
22	5034	Spring		1
23	5012	Lead Screw		1
24	5043	Lead Screw Mount		1
25	5004	Micrometer Collar		2
26	5031	Handwheel		1
27	5015	Handle		2
28	BD920N-TS28	Key	3x13	1
29	5023	Feed Spring		1
30	5022	Nut		1
31	BD920N-TS31	Set Screw	M8x6	1
32	BD920N-TS32	Lock Pin	3x12	1
33	5029	Plate		1
34	5035	Pin		1

Tailstock Assembly

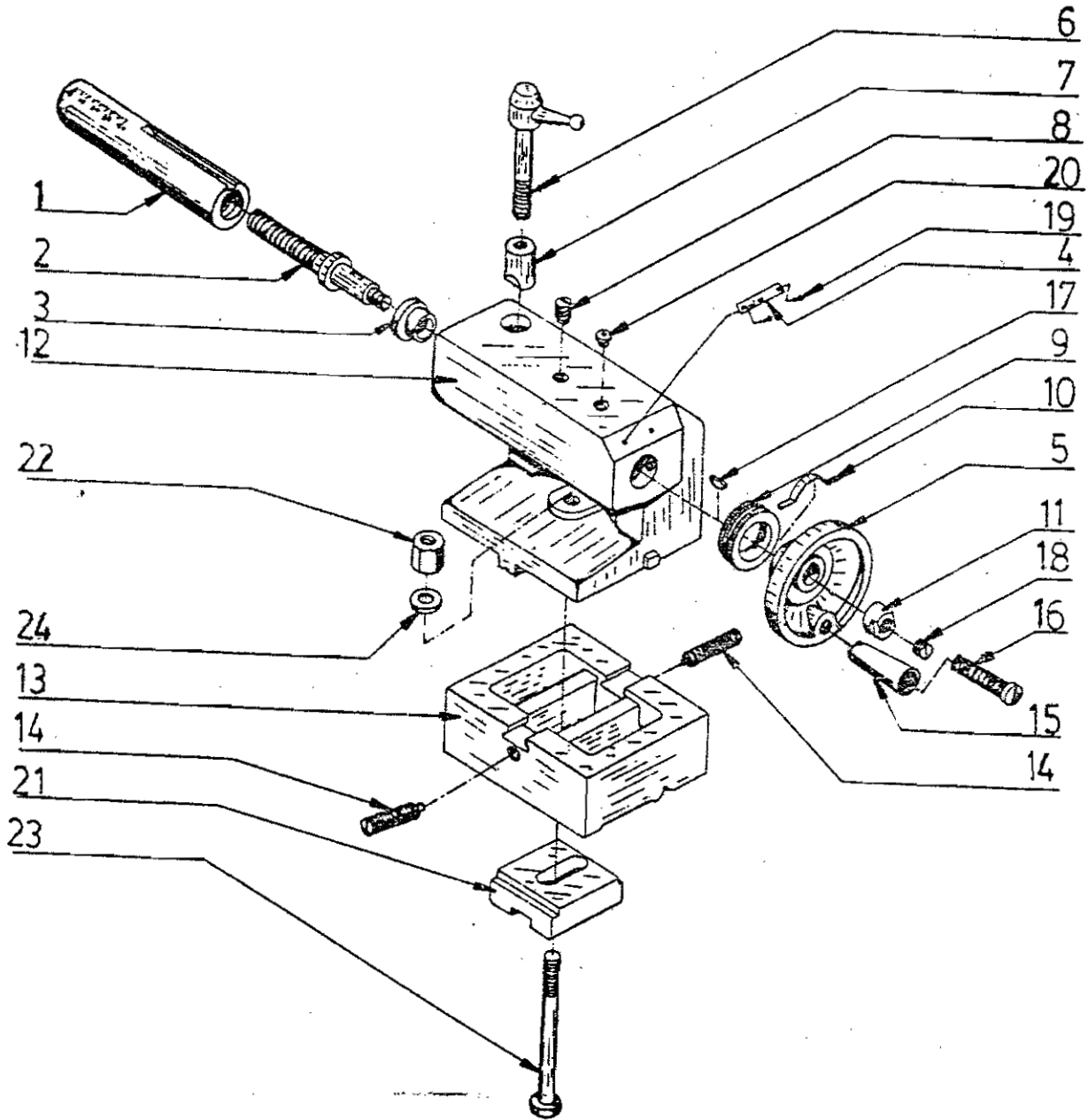

Tailstock Assembly

1	8009	Tailstock Ram		1
2	8010	Leadscrew		1
3	8011	Bushing		1
4	8012	Off Set Indicator Plate		1
5	8013	Hand Wheel		1
6	8008	Lever		1
7	8001	Clamp		1
8	BD920N-T08	Guide Pin	M5x10	1
9	8016	Micrometer Collar		1
10	5023	Feed Spring		1
11	8014	Nut		1
12	8005	Tailstock Body		1
13	8002	Tailstock Base		1
14	TS-152406	Set Screw	M8x25	2
15	4001	Handle		1
16	4002	Screw		1
17	BD920N-T17	Key	3x13	1
18	TS-152401	Set Screw	M8x8	1
19	BD920N-T19	Rivet		2
20	BD920N-T20	Oil Port	6	1
21	8015	Clamping Plate		2
22	8006	Nut	M8	1
23	8007	Screw		1
24	TS-1550061	Washer	M8	1

Center Rest Assembly

1.....	F1001.....	Rest Casting.....	1
2.....	F1002.....	Jaw.....	3
3.....	F1003.....	Screw.....	3
4.....	TS-155108.....	Lock Washer.....	M8..... 3
5.....	TS-1540061.....	Nut.....	M8..... 3
6.....	F1004.....	Adjusting Screw.....	3
7.....	F1005.....	Clamping Plate.....	1
8.....	TS-1490111.....	Hex Cap Boll.....	M8x60..... 1
9.....	TS-1550061.....	Washer.....	M8..... 1

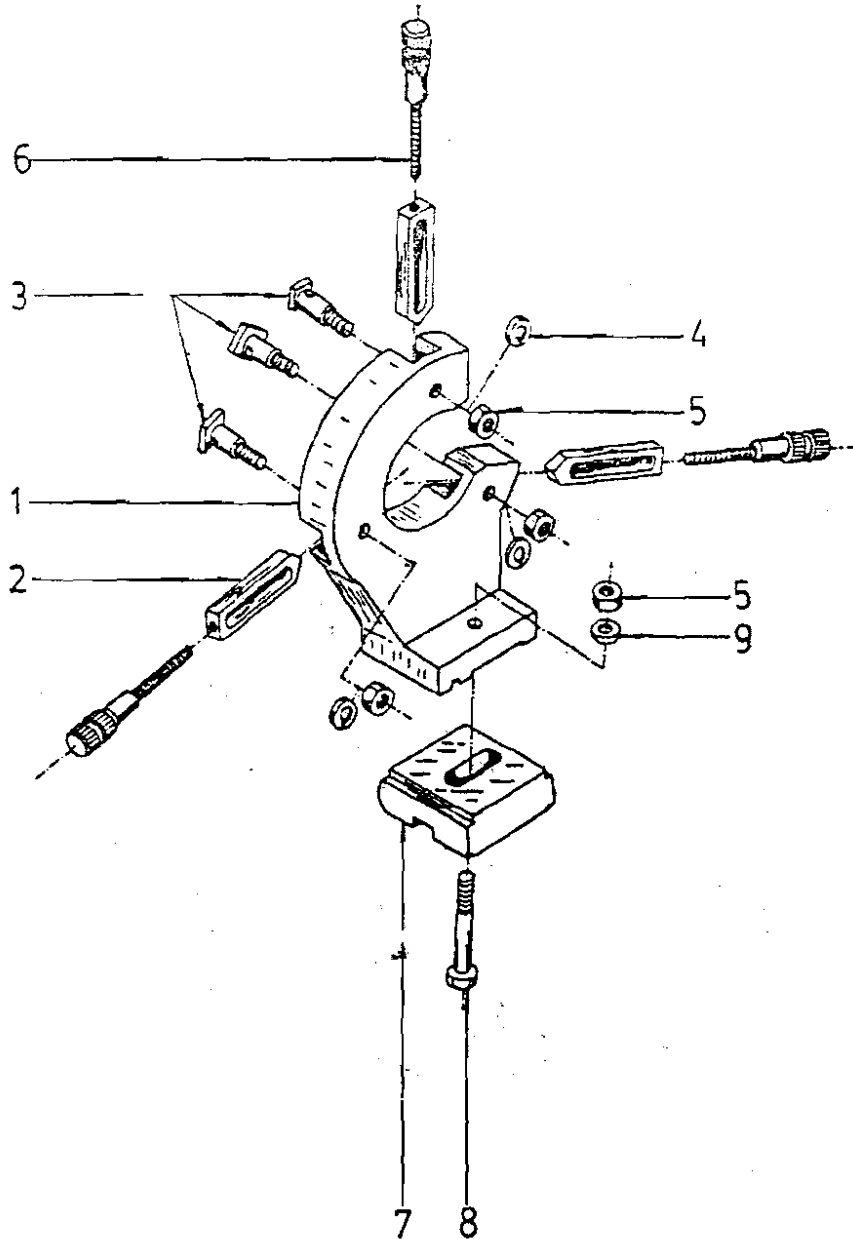

Travel Rest Assembly

1.....	F2001.....	Rest Casting.....	1
2.....	F2002.....	Jaw.....	2
3.....	F2003.....	Screw.....	2
4.....	F2004.....	Adjusting Screw.....	2
5.....	TS-1540061.....	Hex Nut.....	M8 2
6.....	TS-1551081.....	Lock Washer.....	M8 2
7.....	TS-150307.....	Hex Socket Cap Screw.....	M6x30 2
8.....	TS-1550041.....	Washer.....	M6 2

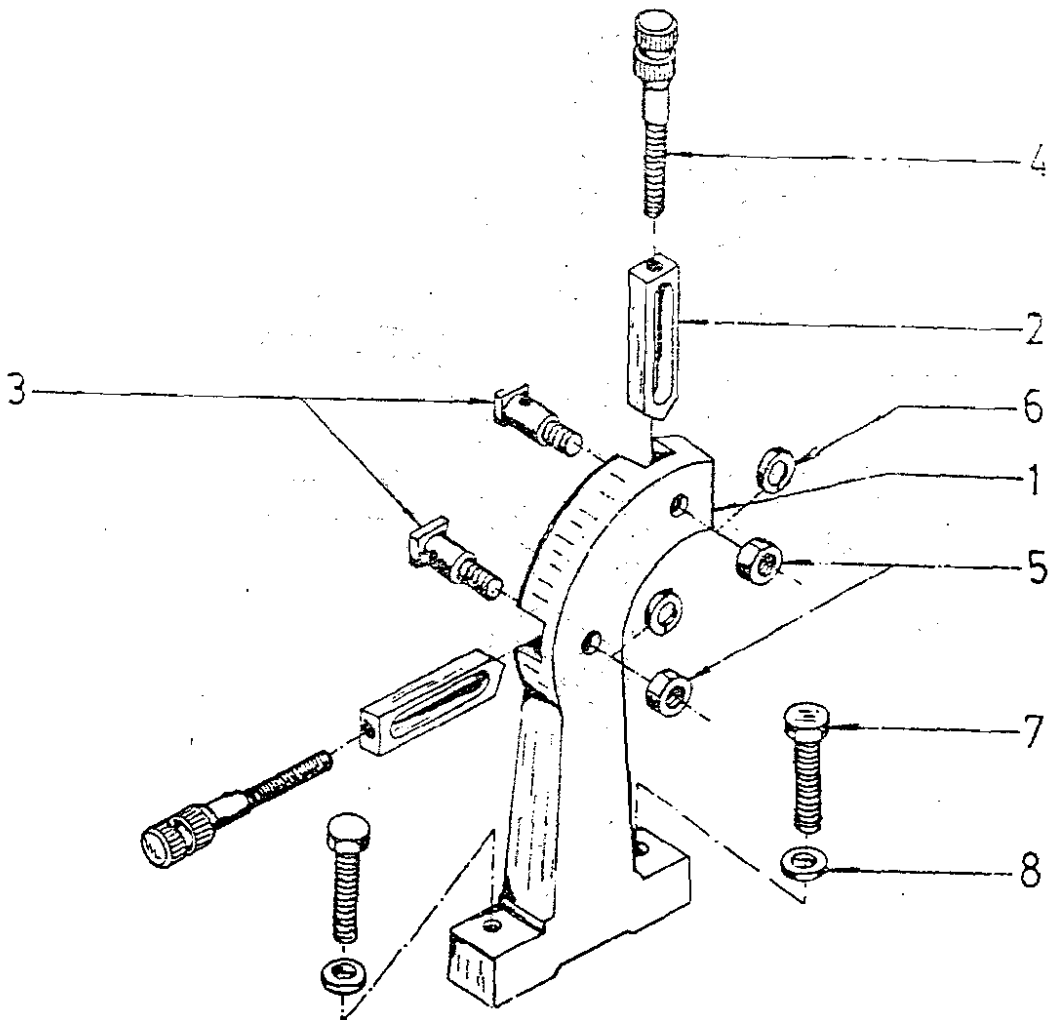

Lathe Bed Assembly

1.....	7001	Bed	1
2.....	7002	Rack	1
3.....	TS-150102	Hex Socket Cap Screw	M4x8	6
4.....	7003	Leadscrew	1
5.....	7004	Bracket	1
6.....	BD920N-B06	Oil Port	6	1
7.....	TS-1503051	Hex Socket Cap Screw	M6x20	2
8.....	7006	Nut	1
9.....	BD920N-B09	Set Screw	M8x6	1
10.....	7005	Stud	M8x28	4
11.....	TS-1540061	Hex Nut	M8	4
12.....	TS-1523071	Set Screw	M6x25	4
13.....	TS-1551041	Lock Washer	M6	4
14.....	TS-1540041	Hex Nut	M6	4

